

Security Guide

Xerox® AltaLink® B8045/B8055/B8065/B8075/B8090,
C8030/C8035/C8045/C8055/C8070 Multifunction Products



© 2019 Xerox Corporation. All rights reserved. Xerox®, CentreWare®, FreeFlow®, AltaLink®, Xerox Extensible Interface Platform® are trademarks of Xerox Corporation in the United States and/or other countries. BR27383

Other company trademarks are also acknowledged.

Document Version: 1.0 (September 2019).

Copyright protection claimed includes all forms and matters of copyrightable material and information now allowed by statutory or judicial law or hereinafter granted including without limitation, material generated from the software programs which are displayed on the screen, such as icons, screen displays, looks, etc.

Changes are periodically made to this document. Changes, technical inaccuracies, and typographic errors will be corrected in subsequent editions.

Table of Contents

1. Introduction	v
Purpose	v
Target Audience	v
Disclaimer	v
2. Product Description	2-1
Physical Components	2-1
Architecture	2-2
User Interface	2-2
Scanner	2-2
Marking Engine	2-2
Controller	2-3
Controller External Interfaces	2-3
Front Panel USB (Type A) prot(s)	2-3
10/100/1000 MB Ethernet RJ-45 Network Connector	2-3
Rear USB (Type B) Target Port	2-3
Optional Equipment.....	2-3
RJ-11 Analog Fax and Telephone	2-3
Wireless Network Connector.....	2-4
Near Field Communications (NFC) Reader	2-4
SMART CARD – CAC/PIV	2-4
Foreign Product Interface.....	2-4
3. User Data Protection.....	3-1
User Data Protection While Within Product	3-1
Encryption	3-1
Trusted Platform Module (TPM Chip)	Error! Bookmark not defined.
Media Sanitization (Image Overwrite)	3-1
Overwriting Immediate Image Overwrite.....	3-1
On-Demand Image Overwrite	3-1
User Data in Transit	3-2
Inbound User Data (Print Job Submission).....	3-2
Scanning to Network Repository, Email, Fax Server (Outbound User Data)	3-3
Scanning to User Local USB Storage Product (Outbound User Data).....	3-3

Add on Apps – Cloud, Google, DropBox, and others (Outbound User Data).....	3-4
4. Network Security	4-1
TCP/IP Ports and Services	4-1
Listening Services (inbound ports).....	4-2
Network Encryption	4-3
IPSec.....	4-3
Wireless 802.11 Wi-Fi Protected Access (WPA)	4-3
TLS.....	4-4
Public Key Encryption (PKI)	4-4
Device Certificates	4-5
Trusted Certificates	4-6
Certificate Validation	4-6
Email Signing and Encryption using S/MIME.....	4-7
SNMPv3	4-7
Network Access Control.....	4-8
802.1x.....	4-8
Cisco Identity Services Engine (ISE)	4-8
Contextual Endpoint Connection Management	4-9
FIPS140-2 Compliance Validation	4-9
Additional Network Security Controls.....	4-10
Endpoint Firewall Options	4-10
IPFiltering	4-10
Stateful Firewall (Advanced IP Filtering).....	4-10
Personal Identifiable Information (PII).....	4-10
5. Device Security: BIOS, Firmware, OS, Runtime, and Operational Security Controls	5-1
Pre-Boot BIOS Protection	Error! Bookmark not defined.
BIOS.....	Error! Bookmark not defined.
Embedded Encryption.....	Error! Bookmark not defined.
Boot Process Integrity	Error! Bookmark not defined.
Firmware Integrity & Verification	Error! Bookmark not defined.
Event Monitoring & Logging	Error! Bookmark not defined.
Runtime Intrusion Prevention & Detection	Error! Bookmark not defined.
Runtime Executable Control	Error! Bookmark not defined.
Runtime Intrusion Detection – Memory Control	Error! Bookmark not defined.
Event Monitoring & Logging	Error! Bookmark not defined.

Continuous Operational Security	Error! Bookmark not defined.
Firmware and Diagnostic Security Controls	Error! Bookmark not defined.
Fail Secure Vs Fail Safe.....	Error! Bookmark not defined.
Pre-Boot Security	5-1
BIOS	5-1
Embedded Encryption	5-1
Boot Process Security.....	5-1
Firmware Integrity	5-1
Runtime Security.....	5-2
Event Monitoring and Logging	5-3
Audit Log	5-3
Operational Security.....	5-3
Firmware Restrictions	Error! Bookmark not defined.
Service Technician (CSE) Access Restriction	5-3
Additional Service Details	5-3
Backup and Restore (Cloning)	5-4
EIP Applications	5-4
6. Configuration and Security Policy Management Solutions	6-1
7. Identification, Authentication, and Authorization	7-1
Authentication	7-1
Local Authentication	7-1
Password Policy	7-2
Network Authentication	7-2
Smart Card Authentication	7-2
Convenience Authentication	7-2
Simple Authentication (non-secure).....	Error! Bookmark not defined.
Authorization (Role Based Access Controls)	7-3
Remote Access	7-3
Local Access	7-3
8. Additional Information and Resources	8-1
Security @ Xerox®	8-1
Responses to Known Vulnerabilities.....	8-1
Additional Resources	8-1
9. Appendix A: Product Security Profiles	9-2
AltaLink B8045/B8055/B8065/B8075/B8090	9-2

Physical Overview	9-2
Security Related Interfaces	9-3
Encryption and Overwrite	9-3
Controller Non-Volatile Storage	9-3
Controller Volatile Memory	9-4
Marking Engine Non-Volatile Storage	9-4
Marking Engine Volatile Memory	9-4
AltaLink C8030/C8035/C8045/C8055/C8070	9-5
Physical Overview	9-5
Security Related Interfaces	9-6
Encryption and Overwrite	9-6
Controller Non-Volatile Storage	9-6
Controller Volatile Memory	9-7
Marking Engine Non-Volatile Storage	9-7
Marking Engine Volatile Memory	9-7
10. Appendix B: Security Events	10-1
Xerox AltaLink Security Events	10-1

1. Introduction

Purpose

The purpose of this document is to disclose information for the AltaLink® multifunction devices (hereinafter called as “the product” or “the system”) with respect to product security. Product Security, for this paper, is defined as how image data is stored and transmitted, how the product behaves in a network environment, and how the product may be accessed both locally and remotely. The purpose of this document is to inform Xerox customers of the design, functions, and features of the product with respect to Information Assurance. This document does not provide tutorial level information about security, connectivity, or the product’s features and functions. This information is readily available elsewhere. We assume that the reader has a working knowledge of these types of topics.

Target Audience

The target audience for this document is Xerox field personnel and customers concerned with IT security.

Disclaimer

The content of this document is provided for information purposes only. Performance of the products referenced herein is exclusively subject to the applicable Xerox Corporation terms and conditions of sale and/or lease. Nothing stated in this document constitutes the establishment of any additional agreement or binding obligations between Xerox Corporation and any third party.

2. Product Description

Physical Components

AltaLink® products consist of an input document handler and scanner, marking engine, controller, and user interface. A typical configuration is depicted below. Please note that options including finishers, paper trays, document handlers, etc. may vary configuration, however, they are not relevant to security and are not discussed.

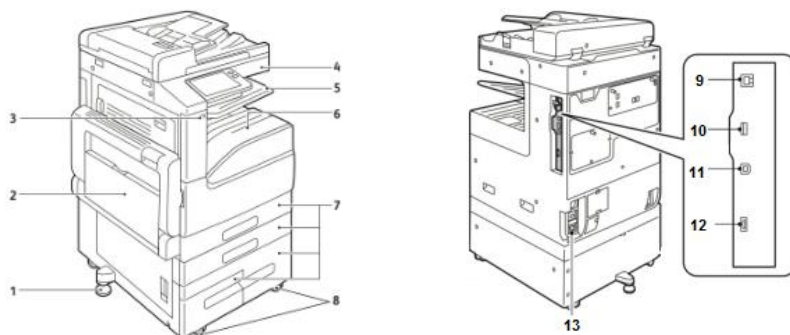

- | | |
|---------------------------------|--|
| 1. Stabilizer. | 8. Caster wheels. |
| 2. Bypass paper feed tray. | 9. Rear USB Port(s)* |
| 3. Front USB Port(s)* | 10. Optional Wi-Fi dongle port* |
| 4. Touch screen user interface. | 11. RJ45 Ethernet connection* |
| 5. Upper paper tray. | 12. Service port
(May require disassembly to access). |
| 6. Lower paper tray. | 13. AC Power |
| 7. Paper feed trays. | |

*Denotes a security related component

Architecture

AltaLink® products share a common architecture which is depicted below. The following sections describe components in detail.

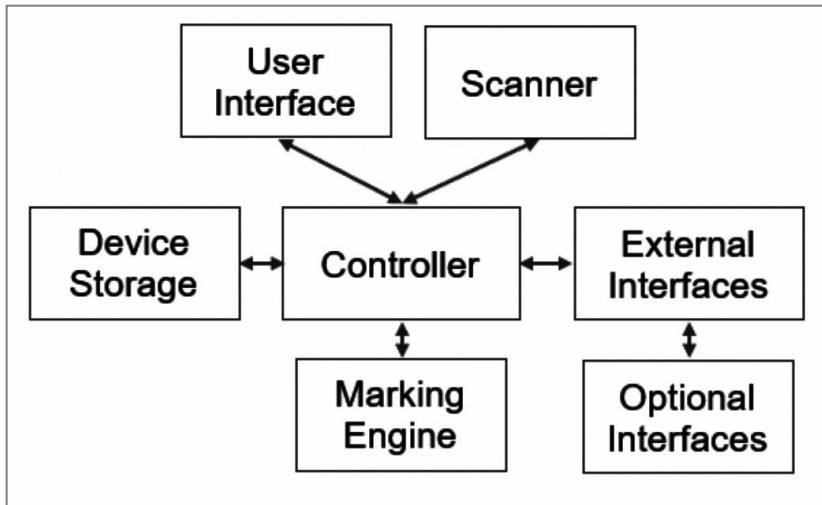

User Interface

The user interface detects soft and hard button actuations and provides text and graphical prompts to the user. The user interface is sometimes referred to as the Graphical User Interface (GUI) or Local UI (LUI) to distinguish it from the remote web server interface (WebUI).

The user interface allows users to access product services and functions. Users with administrative privileges can manage the product configuration settings. User permissions are configurable through Role Based Access Control (RBAC) policies, described in section 7 Identification, Authentication, and Authorization

Scanner

The scanner converts documents from hardcopy to electronic data. A document handler moves originals into a position to be scanned. The scanner provides enough image processing for signal conditioning and formatting. The scanner does not store scanned images.

Marking Engine

The Marking Engine performs copy/print paper feeding and transport, image marking, fusing, and document finishing. The marking engine is comprised of paper supply trays and feeders, paper transport, LED scanner, xerographics, and paper output and finishing. The marking engine is only accessible to the Controller via inter-chip communication with no other access and does not store user data.

Controller

The controller manages document processing using proprietary hardware and algorithms to process documents into high-quality electronic and/or printed reproductions. Documents may be temporarily buffered in RAM during processing. Some models may be equipped with additional storage options such as magnetic Hard Disk Drive (HDD), SD Card. For model specific details please see Appendix A: Product Security Profiles. AltaLink® products encrypt user data and include media sanitization (overwrite) options that ensure that erased data cannot be recovered, described further in section 3 User Data Protection.

In addition to managing document processing the controller manages all network functions and services. Details can be found in section Network Security.

The controller handles all I/O communications with connected products. The following section provides a description of each interface. Please note that not all interfaces are supported on all models; details about each model can be found in Appendix A: Product Security Profiles.

Controller External Interfaces

Front / Rear Panel USB (Type A) port(s)

One or more USB ports may be located on the front of the product, near the user interface. Front USB ports may be enabled or disabled by a system administrator. The front USB port supports the following:

- Walk-up users may insert a USB thumb drive to store or retrieve documents for scanning and/or printing from a FAT formatted USB device. The controller will only allow reading/writing of a limited set of known document types (such as, PDF, PNG, JPEG, TIFF, etc.). Other file types including binary executables are not supported.

Note: Features that use the USB ports (such as Scan To USB) can be disabled independently.

- Connection of optional equipment such as NFC or CAC readers.
- Firmware updates may be submitted through the USB ports. (Note that the product must be configured to allow local firmware updates, or the update will not be processed.)

10/100/1000 MB Ethernet RJ-45 Network Connector

This is a standard RJ45 Ethernet network connector and conforms to IEEE Ethernet 802.3 standards.

Rear USB (Type B) Target Port

A USB type B port located on the controller board at the rear of the product. This port supports the following:

- USB target connector used for printing

Note: This port cannot be disabled completely by a system administrator.

Optional Equipment

RJ-11 Analog Fax and Telephone

The analog fax module connects to the controller. The fax connection supports the Fax Modem T.30 protocol only and will not accept data or voice communication attempts. An external (EXT) is

available to connect an external handset. In this configuration, the FAX card acts as a passive relay.

Wireless Network Connector

AltaLink® products accept an optional wireless kit that can be installed in the rear USB port.

Near Field Communications (NFC) Reader

AltaLink® products come standard with an NFC Chip built into the front panel. This is read only from man NFC client. The data exchanged is not encrypted and may include information including system network status, IP address and product location. NFC functionality can be disabled using the embedded web server of the product. NFC functionality requires a software plugin that can be obtained from Xerox sales and support.

Information shared over NFC includes: IPv4 Address, IPv6 Address, MAC Address, UUID (a unique identifier on the NFC client), and Fully qualified domain name

SMART CARD – CAC/PIV

AltaLink® products support CAC/PIV login or SIPR network access.

Foreign Product Interface

This port is used to connect optional equipment to control access to the machine. A typical application is a coin-operated product where a user must deposit money to enable the machine to print. The information available via the Foreign Product Interface is limited to optically-isolated pulses that can be used to count impressions marked on hardcopy sheets. No user data is transmitted to or from this interface.

3. User Data Protection

Xerox printers and multifunction products receive, process, and may optionally store user data from several sources including as local print, scan, fax, or copy jobs or mobile and cloud applications, etc. Xerox products protect user data being processed by employing strong encryption. When the data is no longer needed, the Image Overwrite (IIO) feature automatically erases and overwrites the data on magnetic media, rendering it unrecoverable. As an additional layer of protection, an extension of IIO called On-Demand Image Overwrite (ODIO) can be invoked to securely wipe all user data from magnetic media.

User Data Protection While Within Product

This section describes security controls that protect user data while it is resident within the product. For a description of security controls that protect data in transit please refer to the following section that discusses data in transit; also, the Network Security section of this document.

Encryption

All user data being processed or stored to the product is encrypted by default. Note that encryption may be disabled to enhance performance on AltaLink® products (though this is not recommended in secure environments).

The algorithm used in the product is AES-256. The encryption key is automatically created at start up and stored in the RAM. The key is deleted by a power-off, due to the physical characteristics of the RAM.

Media Sanitization (Image Overwrite)

AltaLink® products equipped with magnetic hard disk drives are compliant with NIST Special Publication 800-88 Rev1: Guidelines for Media Sanitization. User data is securely erased using a three-pass algorithm as described in the following link:

<https://nvlpubs.nist.gov/nistpubs/specialpublications/nist.sp.800-88r1.pdf>

Overwriting Immediate Image Overwrite

When enabled, Immediate Image Overwrite (IIO) will overwrite any temporary files that were created on the magnetic hard disk that may contain user data. The feature provides continuous automatic of sensitive data with minimal impact to performance, robust error reporting, and logging via the Audit Log.

On-Demand Image Overwrite

Complementing the Immediate Image Overwrite is On-Demand Overwrite (ODIO). While IIO overwrites individual files, ODIO overwrites entire partitions. The ODIO feature can be invoked at any time and optionally may be scheduled to run automatically.

User Data in Transit

This section focuses on the protection of user data (print/scan/other jobs) in transit as they are submitted to the product for processing and/or are sent from the product to other systems. Additional protections are also discussed in the Network Security section of this document.

Inbound User Data (Print Job Submission)

In addition to supporting network level encryption including IPsec and WPA Xerox products also support encryption of print job data at the time of submission. This can be used to securely transmit print jobs over unencrypted connections or to enhance existing network level security controls.

Encrypted Transport	Description
IPPS (TLS)	Submit print jobs via Secure Internet Printing Protocol. This protocol is based on HTTP and utilizes the TLS suite to encrypt data.
HTTPS (TLS)	Securely submit a print job directly to product via the built-in web server.
Xerox Print Stream Encryption	The Xerox Global Print Driver® supports document encryption for any print jobs to enabled products. Simply configure Document Encryption to On in the Advanced tab of the print driver at print time.

Scanning to Network Repository, Email, Fax Server (Outbound User Data)

AltaLink® multifunction products support scanning of hardcopy documents to external network locations including file repositories and email and facsimile services. In addition to supporting network level encryption including IPsec Xerox products support the following.

Protocol	Encryption	Description
HTTP	N/A	Unencrypted HTTP protocol.
HTTPS (TLS)	TLS	HTTP encrypted by TLS
FTP	N/A	Unencrypted FTP.
SFTP (SSH)	SSH	FTP encrypted by SSH.
SMBv3	N/A	Encryption may be enabled on a Windows share. AltaLink® products currently support SMB encryption.
SMBv2	N/A	Unencrypted SMB
SMBv1	N/A	(Not used as a transport protocol. Used for network discovery only)
SMTP (email)	S/MIME	The product uses SMTP to transmit data to the email server. Email authentication, encryption, and signing are supported. Please refer to the Network Security section of this document for details.

Scanning to User Local USB Storage Product (Outbound User Data)

Scan data is transferred directly to the user's USB product. Filesystem encryption of user products are not supported.

Add on Apps – Cloud, Google, DropBox, and others (Outbound User Data)

The Xerox App Gallery® contains several additional applications that extend the capabilities of Xerox products. Discussion of App security is beyond the scope of this document. Xerox Apps utilize the security framework provided by the third-party vendor. (For example, Microsoft O365 or Google apps would utilize Microsoft and Google's security mechanisms respectively). Please consult documentation for individual Apps and third-party security for details.

		AltaLink® Multifunction
		B8045, B8055, B8065, B8075, B8090, C8030, C8035, C8045, C8055, C8070
Local Data Encryption (HDD, IC)		AES-256
Federal Information Protection Standard 140-2		Yes
Media Sanitization NIST 800-171 (Image Overwrite)		Models with magnetic HDD. See Appendix A: Product Security Profiles
Print Submission		
	IPPS (TLS)	Supported
	HTTPS (TLS)	Supported
	Xerox Print Stream Encryption	Supported
Scan to Repository Server		
	HTTPS (TLS)	1.2
	SFTP (SSH)	SSH-2
	SMB (unencrypted)	v1, v2, v3
	SMB (with share encryption enabled)	V3
	HTTP (unencrypted)	Supported
	FTP (unencrypted)	Supported
Scan to Fax Server		
	HTTPS (TLS)	1.2
	SFTP (SSH)	SSH-2
	SMB (unencrypted)	v1, v2, v3
	SMB (with share encryption enabled)	V3
	S/MIME	Supported
	HTTP (unencrypted)	Supported
	FTP (unencrypted)	Supported
	SMTP (unencrypted)	Supported
Scan to Email		
	S/MIME	Supported
	SMTP (unencrypted)	Supported
	TLS (Start TLS)	Supported

4. Network Security

Xerox products are designed to offer a high degree of security and flexibility in almost any network environment. This section describes several aspects of the product related to network security.

TCP/IP Ports and Services

Xerox devices are robust, offering support for a wide array of services and protocols. The devices are capable of hosting services as well as acting as a client for others. The diagram below presents a high-level overview of inbound communications (from other hosts on the network into listening services on the device) and outbound connections initiated by the device (acting as a client to external network services).



Listening Services (inbound ports)

The following table summarizes all potentially open ports on the product. These ports can be enabled/disabled within the product configuration.

Port	Type	Service Name
80 or 443	TCP	HTTP including: Web User Interface UPnP Discovery Web Services for Products (WSD) WebDAV
68	UDP	DHC ACK Response to DHCP
88	UDP	Kerberos
110	TCP	POP3
139	TCP	NETBIOS
161	TCP	SNMP
162	TCP	SNMP Trap
631 or 443	TCP	HTTP (IPP)
137	UDP	NETBIOS (Name Service)
138	UDP	NETBIOS (Datagram Service)
161	UDP	SNMP
427	TCP/UDP	SLP
445	TCP	SMB
500 & 4500	TCP/UDP	IPSec
515	TCP	LPR
631	TCP	IPP
3702	TCP	WSD (Discovery)
5353	TCP or UDP	mDNS
5354	TCP	mDNS Responder IPC
9100	TCP	Raw IP (also known as JetDirect, AppSocket or PDL-datastream)
5909-5999	TCP	Remote Access to local display panel. Port is randomly selected and communications encrypted with TLS 1.2.
51333	TCP	Device File Distribution downloads
53202	TCP	WSD Transfer
53303	TCP	WSD Print
53404	TCP	WSD Scan

Network Encryption

IPSec

Internet Protocol Security (IPsec) is a network security protocol capable of providing encryption and authentication at the packet level. AltaLink® products support IPSec for both IPv4 and IPv6 protocols.

		AltaLink® Multifunction B8045, B8055, B8065, B8075, B8090, C8030, C8035, C8045, C8055, C8070
IPSec		
	Supported IP Versions	IPv4, IPv6
	Key exchange authentication method	Preshared Key & digital signature authentication (device authentication certificate, server validation certificate)
	Transport Mode	Transport & Tunnel mode
	Security Protocol	ESP & AH
	ESP Encryption Method	AES, 3DES, Null
	ESP Authentication Methods	SHA1, SHA256, None

Wireless 802.11 Wi-Fi Protected Access (WPA)

Products equipped with WiFi support WPA2 Personal, WPA2 Enterprise, and Mixed Mode compliant with IEEE 802.11i. The wireless network adapters used in Xerox products are certified by the Wi-Fi Alliance.

		AltaLink® Multifunction B8045, B8055, B8065, B8075, B8090, C8030, C8035, C8045, C8055, C8070
Wi-Fi (802.11)		
	No Encryption	Supported
	WEP	RC4
	WPA2 Personal (PSK)	CCMP (AES), TKIP, TKIP+CCMP (AES)
	WPA2 Enterprise	CCMP (AES), TKIP, TKIP+CCMP (AES) -- PEAPv0 MS-CHAPv2 EAP-TLS EAP-TTLS/PAP EAP-TTLS/MS-CHAPv2 EAP-TTLS/EAP-TLS
	BSSID Roaming Restriction	Supported

TLS

AltaLink® products support the latest version, TLS 1.2.

AltaLink® Multifunction		
B8045, B8055, B8065, B8075, B8090, C8030, C8035, C8045, C8055, C8070		
TLS Versions Supported		
	Product Web Interface	1.2, 1.1, 1.0
	Product Web Services	1.2, 1.1, 1.0
	Product IPPS printing	1.2, 1.1, 1.0
	Remote control	1.2

Public Key Encryption (PKI)

A digital certificate is a file that contains data used to verify the identity of the client or server in a network transaction. A certificate also contains a public key used to create and verify digital signatures. To prove identity to another product, a product presents a certificate trusted by the other product. The product can also present a certificate signed by a trusted third party and a digital signature proving that it owns the certificate.

A digital certificate includes the following data:

- Information about the owner of the certificate
- The certificate serial number and expiration date
- The name and digital signature of the certificate authority (CA) that issued the certificate
- A public key
- A purpose defining how the certificate and public key can be used
- There are four types of certificates:
 - A Product Certificate is a certificate for which the printer has a private key. The purpose specified in the certificate allows it to be used to prove identity.
 - A CA Certificate is a certificate with authority to sign other certificates.
 - A Trusted Certificate is a self-signed certificate from another product that you want to trust.
 - A domain controller certificate is a self-signed certificate for a domain controller in your network. Domain controller certificates are used to verify the identity of a user when the user logs in to the product using a Smart Card.

For protocols such as HTTPS, the printer is the server, and must prove its identity to the client Web browser. For protocols such as 802.1X, the printer is the client, and must prove its identity to the authentication server, typically a RADIUS server.

Device Certificates

AltaLink® products support both CA signed and self-signed certificates. Product certificates support a bit length of up to 2048 bits.

A CA signed certificate can be created by generating a Certificate Signing Request (CSR), and sending it to a CA or a local server functioning as a CA to sign the CSR. An example of a server functioning as a certificate authority is Windows Server 2008 running Certificate Services. When the CA returns the signed certificate, install it on the printer.

Alternatively, a self-signed certificate may be created. When you create a Product Certificate, the product generates a certificate, signs it, and creates a public key used in SSL/TLS encryption.

AltaLink® Multifunction		
B8045, B8055, B8065, B8075, B8090, C8030, C8035, C8045, C8055, C8070		
Device Certificates		
	Certificate Length	1024, 2048
	Supported Hashes	SHA1, SHA256
	Product Web Server	Supported
	IPPS (TLS) Printing	Supported
	802.1X Client	Supported
	Email Signing	Supported
	Email Encryption	Supported
	OCSP Signing	Supported
	IPSec	Supported
	SFTP	Supported

Trusted Certificates

Public certificates may be imported to the product's certificate store for validation of trusted external products. The following categories are supported:

- A Trusted Root CA Certificate is a certificate with authority to sign other certificates. These certificates usually are self-signed certificates that come from another product or service that you want to trust.
- An Intermediate CA Certificate is a certificate that links a certificate to a Trusted Root CA Certificate in certain network environments.
- Other Certificates are certificates that are installed on the printer for solution-specific uses.

An administrator can specify the minimum encryption key length required for certificates. If a user attempts to upload a certificate that contains a key that does not meet this requirement, a message appears. The message alerts the user that the certificate they are attempting to upload does not meet the key length requirement.

AltaLink® Multifunction	
B8045, B8055, B8065, B8075, B8090, C8030, C8035, C8045, C8055, C8070	
Trusted Certificates	
Minimum Length Restriction Options	None, 1024, 2048
Maximum Length	4096
Supported Hashes	SHA1/224/256/384/512
Supported Formats	.cer, .crt, .der, .pem, PKCS#7 (.p7b), PKCS#12 (.pfx, .p12)
IPSec	Supported
LDAP	Supported
Scanning (HTTPS/TLS)	Supported
Scanning (SFTP/SSH)	Used for audit log transfer
802.1X Client	Supported
Email Signing	Supported
Email Encryption	Supported
OCSP Signing	Supported

Certificate Validation

AltaLink® devices support certificate validation with configurable checks for OSCP.

Validation checks include:

- Validation of certificate path
- Certificate expiration
- Validation of trusted CA
- Signature validation

Email Signing and Encryption using S/MIME

S/MIME (Secure/Multipurpose Internet Mail Extensions) provides Authentication, Message integrity, Non-repudiation, and encryption of email.

AltaLink® Multifunction		
B8045, B8055, B8065, B8075, B8090, C8030, C8035, C8045, C8055, C8070		
Email S/MIME		
	Versions	v3
	Digest	SHA1, SHA256, SHA384, SHA512
	Encryption	3DES, AES128, AES192, AES256

SNMPv3

SNMPv3 is the current standard version of SNMP defined by the Internet Engineering Task Force (IETF). It provides three important security features:

- Message integrity to ensure that a packet has not been tampered with in transit
- Authentication to verify that the message is from a valid source
- Encryption of packets to prevent unauthorized access

AltaLink® Multifunction		
B8045, B8055, B8065, B8075, B8090, C8030, C8035, C8045, C8055, C8070		
SNMPv3		
	Digest	SHA1, MD5
	Encryption	DES, AES128

Network Access Control

802.1x

In 802.1X authentication, when the product is connected to the LAN port of Authenticator such as the switch as shown below, the Authentication Server authenticates the product, and the Authenticator controls access of the LAN port according to the authentication result. The product starts authentication processing at startup when the startup settings for 802.1X authentication are enabled.

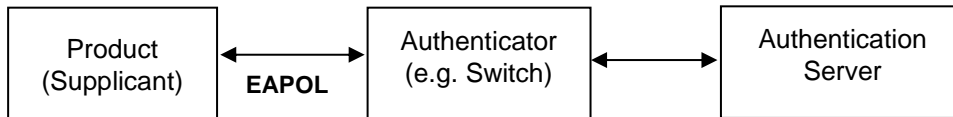

AltaLink® Multifunction		
B8045, B8055, B8065, B8075, B8090, C8030, C8035, C8045, C8055, C8070		
Network Access Control		
	802.1x	Supported
	Authentication Methods	EAP-MD5, PEAPv0/EAP MSCHAPv2, EAP-MSCHAPv2, EAP-TLS

Cisco Identity Services Engine (ISE)

Cisco ISE is an intelligent security policy enforcement platform that mitigates security risks by providing a complete view of which users and what products are being connected across the entire network infrastructure. It also provides control over what users can access your network and where they can go. Cisco's ISE includes over 200 Xerox product profiles that are ready for security policy enablement. This allows ISE to automatically detect Xerox products in your network. Xerox products are organized in Cisco ISE under product families, such as AltaLink® products, enabling Cisco ISE to automatically detect and profile new Xerox products from the day they are released. Customers who use Cisco ISE find that including Xerox products in their security policies is simpler and requires minimal effort.

Cisco ISE Profiling Services provides dynamic detection and classification of endpoints connected to the network. ISE collects various attributes for each network endpoint to build an endpoint database. The classification process matches the collected attributes to prebuilt or user-defined conditions, which are then correlated to an extensive library of product profiles. These profiles include a wide range of product types, including tablets, smartphones, cameras, desktop operating systems (for example, Windows®, Mac OS® X, Linux® and others), and workgroup systems such as Xerox printers and MFPs.

Once classified, endpoints can be authorized to the network and granted access based on their profile signature. For example, guests to your network will have different level of access to printers and other end points in your network. As an example, you and your employees can get full printer access when accessing the network from a corporate workstation but be granted limited printer access when accessing the network from your personal Apple® iPhone®.

Cisco ISE allows you to deploy the following controls and monitoring of Xerox products:

- Automatically provision and grant network access rights to printers and MFPs to prevent inappropriate access (including automatically tracking new printing products connecting to the network):
 - Block non-printers from connecting on ports assigned to printers
 - Prevent impersonation (aka spoofing) of a printer/MFP
 - Automatically prevent connection of non-approved print products
 - Smart rules-based policies to govern user interaction with network printing products
- Provide simplified implementation of security policies for printers and MFPs by:
 - Providing real time policy violation alerts and logging
 - Enforcing network segmentation policy
 - Isolating the printing products to prevent general access to printers and MFPs in restricted areas
- Automated access to policy enforcement
 - Provide extensive reporting of printing product network activity

AltaLink® Multifunction		
B8045, B8055, B8065, B8075, B8090, C8030, C8035, C8045, C8055, C8070		
Network Access Control		
	Cisco ISE	Supported

Contextual Endpoint Connection Management

Traditionally network connection management has been limited to managing endpoints by IP address and use of VLANs and firewalls. This is effective, but highly complex to manage for every endpoint on a network. Managing, maintaining, and reviewing the ACLs (and the necessary change management and audit processes to support them) quickly become prohibitively expensive. It also lacks the ability to manage endpoints contextually.

Connectivity of AltaLink® devices can be fully managed contextually by Cisco TrustSec. TrustSec uses Security Group Tags (SGT) that are associated with an endpoint's user, device, and location attributes. SG-ACLs can also block unwanted traffic so that malicious reconnaissance activities and even remote exploitation from malware can be effectively prevented.

FIPS140-2 Compliance Validation

When enabled, the product will validate its current configuration to identify cryptographic modules in use. Modules which are not FIPS 140-2 (Level 1) compliant will be reported.

AltaLink® products include FIPS compliant algorithms of SNMPv3 and Kerberos, however an exception can be approved to run these in non-FIPS compliant mode when configured for non-FIPS algorithms.

Additional Network Security Controls

Endpoint Firewall Options

		AltaLink® Multifunction
		B8045, B8055, B8065, B8075, B8090, C8030, C8035, C8045, C8055, C8070
Firewall		Stateful Packet Filter
	Supported	(Not currently supported)
	Supported	Supported

IP Filtering

The devices contain a static host-based firewall that provides the ability to prevent unauthorized network access based on IP address and/or port number. Filtering rules can be set by the SA using the WebUI. An authorized SA can create rules to (Accept / Reject / Drop) for ALL or a range of IP addresses. In addition to specifying IP addresses to filter, an authorized SA can enable/disable all traffic over a specified transport layer port.

Stateful Firewall (Advanced IP Filtering)

AltaLink® products support stateful packet inspection that it tracks connections and packet flows. Rules may be configured that examine incoming and outgoing packets. Packets are matched against each rule in order until a match occurs and allows the packet to be accepted, rejected, or dropped.

Personal Identifiable Information (PII)

Personal Identifiable Information (PII) can be entered or stored into the device through several means: address book, scan templates, device description, display device information, audit logs, and engineering logs. The PII is encrypted on the device so not readable outside of the operation of the device. The Admin controls the ability of users to enter data, and controls the accessibility of logs, or the deletion of logs. If users wish not to have any PII stored on the device, the Admin has the ability to restrict the features where PII could be stored and has the ability to restrict access to logs. Users do not have access to the internals of the device (memory, hard drive) where PII may be resident.

5. Device Security: BIOS, Firmware, OS, Runtime, and Operational Security Controls

AltaLink® products have robust security features that are designed to protect the system from a wide range of threats. Below is a summary of some of the key security controls.

Pre-Boot Security

BIOS

The BIOS used in AltaLink® products is embedded and cannot be accessed directly. Unlike devices such as Desktop and Laptop computers that have a BIOS that can be accessed via a keystroke on startup, the BIOS of AltaLink® products it's not accessible.

Many devices can be cleared to factory defaults (including passwords and security settings) by depressing a reset button using a paperclip or similar method. For security reasons, AltaLink® products do not offer such a method to clear or reset the BIOS. (Note that configuration settings may be reset to factory defaults by an authorized administrator, however this does not impact BIOS settings).

BIOS updates are not applied by device firmware updates. Firmware is protected from tampering by use of digital signatures (discussed later in this section).

The BIOS is designed to fail secure. An integrity check is performed immediately when power is applied. If verification is successful, the system proceeds with OS kernel boot. If the integrity check fails, the system will fail secure.

Embedded Encryption

AES encryption is used to protect the system, user data, and configuration (including security settings) from being retrieved or modified. Each device uses its own unique key that is securely generated. Encryption is enabled by default. Media encryption and sanitization are discussed in Section 3 User Data Protection.

Boot Process Security

Firmware Integrity

Unlike open operating systems such as servers and user workstations in which software may be installed by users, Xerox products are based on embedded systems and the contents are managed by Xerox. The only means of modifying the contents of a device is by applying a firmware update package.

Firmware updates use a special format and each firmware update is digitally signed to protect the integrity of the contents. Firmware that is corrupt or has been illicitly modified will be rejected. **This security control cannot be disabled.**

AltaLink® products include a built-in firmware software validation. This is a file integrity monitor that compares the security hashes of currently installed firmware to a secured whitelist that was installed when the signed firmware was installed.

Runtime Security

Each AltaLink® device comes with McAfee Embedded Control built-in and enabled by default. McAfee Embedded Control is used to protect a variety of endpoints that range from wearable devices to critical systems controlling electrical generation.

Executable control prevents unauthorized code from executing. Xerox has defined a whitelist of executable programs; software that is not on the secure whitelist is not allowed to execute.

Memory control monitors memory and running processes. If unauthorized code is injected into a running process, it is detected and prevented.

When an anomaly is detected it is logged to the device audit log and optional alerts are immediately sent via email. Events are also reportable through CentreWare® Web or Xerox Device Manager, and McAfee® ePolicy Orchestrator® (ePO).

Operational Security

Firmware Restrictions

The list below describes supported firmware delivery methods and applicable access controls.

- **Local Firmware Upgrade via USB port:**
Xerox service technicians can update product firmware using a USB port and specially configured USB thumb drive. This ability can be restricted by enabling the Customer Service Engineer Restriction feature which will require entry of a unique, customer designated password in order to accept the update.
- **Network Firmware Update:**
Product system administrators can update product firmware using the Embedded Web Server. The ability to apply a firmware update is restricted to roles with system administrator or Xerox service permissions. Firmware updates can be disabled by a system administrator.
- **Xerox Remote Services Firmware Update:**
Xerox Remote Services can update product firmware securely over the internet using HTTPS. This feature can be disabled, scheduled, and includes optional email alerts for system administrators.

The programs stored in the Flash ROM listed below are downloadable from external sources.

- Controller
- Marking Engine
- Scanner
- Document Feeder
- Finisher (Option for processing printed paper. No description on Finisher is provided in this document because user's image data will not be stored in it.)
- High capacity feeder (No description on High capacity feeder is provided in this document because user's image data will not be stored in it.)
- High capacity stacker (No description on high capacity stacker is provided in this document because user's image data will not be stored in it.)
- Interface Module (No description on interface module is provided in this document because user's image data will not be stored in it.)
- This program-downloading function can be disabled by a system administrator from the local UI.

Event Monitoring and Logging

Audit Log

The Audit Log feature records security-related events. The Audit Log contains the following information:

Field	Description
Index	A unique value that identifies the event.
Date	The date that the event happened in mm/dd/yy format.
Time	The time that the event happened in hh:mm:ss format.
ID	The type of event. The number corresponds to a unique description.
Description	An abbreviated description of the type of event.
Additional Details	Columns 6–10 list other information about the event, such as: Identity: User Name, Job Name, Computer Name, Printer Name, Folder Name, or Accounting Account ID display when Network Accounting is enabled. Completion Status Image Overwrite Status: The status of overwrites completed on each job. Immediate Image must be enabled.

AltaLink® products currently support 159 unique events.

A maximum of 15,000 events can be stored on the device. When the number of events exceeds 15,000, audit log events will be deleted in order of timestamp, and then new events will be recorded. The audit log can be exported at any time by a user with administrative privileges. Note that as a security precaution, audit log settings and data can only be accessed via HTTPS.

Operational Security

Service Technician (CSE) Access Restriction

The CSE (Customer Service Engineer) Access Restriction allows customers to create an additional password that is independent of existing administrator passwords. This password must be supplied to allow service of the product. This password is not accessible to Xerox support and cannot be reset by Xerox service personnel.

Additional Service Details

Xerox products are serviced by a tool referred to as the Portable Service Workstation (PWS). Only Xerox authorized service technicians are granted access to the PWS. Customer documents or files cannot be accessed during a diagnostic session, nor are network servers accessible through this port. If a network connection is required while servicing a Xerox device, service technicians will remove the device from any connected networks. The technician will then connect directly to the device using an Ethernet cable, creating a physically secure and isolated network during service operations.

Backup and Restore (Cloning)

Certain system settings can be captured in a 'clone' file that may be applied to other systems that are the same model. Clone files are encoded but not encrypted and have the potential to contain sensitive information depending on which product feature setting is selected. Access to both create and apply a clone file can be restricted using role-based access controls. Clone files can only be created and applied through the Embedded Web Server.

EIP Applications

Xerox products can offer additional functionality through the Xerox Extensible Interface Platform® (EIP). Third party vendors can create Apps that extend the functionality of a product. Xerox signs EIP applications that are developed by Xerox or Xerox partners. Products can be configured to prevent installation of unauthorized EIP applications.

6. Configuration and Security Policy Management Solutions

Xerox Device Manager and Xerox® CentreWare® Web (available as a free download) centrally manage Xerox Devices. Additionally, AltaLink® products come with McAfee built in and can be managed with McAfee ePO™ providing an enhanced security posture supporting proactive monitoring, threat detection, and remediation capabilities. For details please visit Xerox.com or speak with a Xerox representative.

7. Identification, Authentication, and Authorization

AltaLink® products offer a range of authentication and authorization options to support various environments.

Single Factor authentication is supported locally on the product or via external network authentication servers (e.g., LDAP, Kerberos, ADS). Multi Factor authentication is supported by addition of card reader hardware. (Where ease of access is desired, open access and simple user identification modes also exist, however these are not recommended for secure environments.)

In all modes, product administrator accounts always require authentication. This cannot be disabled.

A flexible RBAC (Role Based Access Control) security model supports granular to assign of user permissions. Once a user has been authenticated, the product grants (or denies) user permissions based upon the role(s) they have been assigned to. Pre-defined roles that may be used or custom roles may be created as desired.

Authentication

AltaLink® devices support the following authentication mode:

- Local Authentication
- Network Authentication
- Smart Card Authentication (CAC, PIV, SIPR, etc.)
- Convenience Authentication

Local Authentication

The local user database stores user credential information. The printer uses this information for local authentication and authorization, and for Xerox® Standard Accounting. When you configure local authentication, the printer checks the credentials that a user provides against the information in the user database. When you configure local authorization, the printer checks the user database to determine which features the user is allowed access. Each device has a unique default administrator password which should be changed as soon as possible along with enabling recommended security features to secure the system.

Note: User names and passwords stored in the user database are not transmitted over the network

Password Policy

The following password attributes can be configured:

Password Policy	
Minimum Length	1
Maximum Length	63
Password cannot contain User Name	Supported
Password complexity options (in addition to alphabetic characters)	Require a number

Network Authentication

When configured for network authentication, user credentials are validated by a remote authentication server.

Network Authentication Providers	
Kerberos (Microsoft Active Directory)	Supported
Kerberos (MIT)	Supported
SMB NTLM Versions Supported	NTLMv2
LDAP Versions Supported	Version 3 (including TLS 1.2)

Smart Card Authentication

Two-factor security –a PIN to unlock the smart card and Kerberos PKINIT authentication using certificates on the smart card combination. Requires optional card reader hardware and software plugin. Authentication is handled by a remote server. Supported remote authentication methods include Kerberos, SMB and LDAP.

Smart Card authentication is considered very secure due to the nature of the Smart Card architecture and potential levels of encryption of data on the card itself.

Support for the SIPR network is provided using a Smart Card authentication solution created by 90meter under contract for Xerox.

Details regarding 90meter can be found online here: <https://www.90meter.com/>

Smart Cards	
Common Access Card (CAC)	Supported
PIV / PIV II	Supported
Gemalto MD	Supported

Convenience Authentication

Convenience authentication offloads authentication to a third-party solution which may offer more or less security than native security implementations. Users swipe a pre-programmed identification card or key fob to access the device.

For example, employees may be issued key fobs for access to facilities. Convenience mode may be configured to allow an employee to authenticate using their fob or require the fob in a multi-factor manor. The level of security provided is dependent upon the chosen implementation.

Some examples of third party convenience authentication providers include:

- Xerox Workplace Cloud : <https://www.xerox.com/>
- Pharos print management solutions: <https://pharos.com/>
- YSoft SafeQ: <https://www.ysoft.com/en>

Contact your Xerox sales representative for details and other options.

Authorization (Role Based Access Controls)

AltaLink® products offer granular control of user permissions. Users can be assigned to pre-defined roles or customers may design highly flexible custom permissions. A user must be authenticated before being authorized to use the services of the product. Authorization ACLs (Access Control Lists) are stored in the local user database. Authorization privileges (referred to as permissions) can be assigned on a per user or group basis.

Please note that Xerox products are designed to be customizable and support various workflows as well as security needs. User permissions include security-related permissions and non-security related workflow permissions (e.g., walkup user options, copy, scan, plex, etc.). Only security-related permissions are discussed here.

Remote Access

Without RBAC permissions defined basic information such as Model, Serial number, and Software Version can be viewed by unauthenticated users. This can be disabled by restricting access to the device website pages for non-logged-in users.

By default, users are allowed to view basic status and support related information, however they are restricted from accessing device configuration settings. Permission to view this information can be disallowed.

Local Access

Without RBAC permissions defined basic information such as Model, Serial number, Software Version, IP address, and Host Name can be viewed without authentication. This can be disabled by disallowing access to device settings for unauthenticated.

By default, users are allowed to access the local interface, however they are restricted from accessing device configuration settings. Roles can be configured to allows granular access to applications, services, and tools. Users can be also restricted from accessing the local interface completely.

8. Additional Information and Resources

Security @ Xerox®

Xerox maintains an evergreen public web page that contains the latest security information pertaining to its products. Please see <https://www.xerox.com/security>.

Responses to Known Vulnerabilities

Xerox has created a document which details the Xerox Vulnerability Management and Disclosure Policy used in discovery and remediation of vulnerabilities in Xerox software and hardware. It can be downloaded from this page: <https://www.xerox.com/information-security/information-security-articles-whitepapers/enus.html>

Additional Resources

Below are additional resources.

Security Resource	URL
Frequently Asked Security Questions	https://www.xerox.com/en-us/information-security/frequently-asked-questions
Common Criteria Certified Products	https://security.business.xerox.com/en-us/documents/common-criteria/
Current Software Release Quick Lookup Table	https://www.xerox.com/security
Bulletins, Advisories, and Security Updates	https://www.xerox.com/security
Security News Archive	https://security.business.xerox.com/en-us/news/

9. Appendix A: Product Security Profiles

This appendix describes specific details of each AltaLink® product.

AltaLink B8045/B8055/B8065/B8075/B8090

Physical Overview

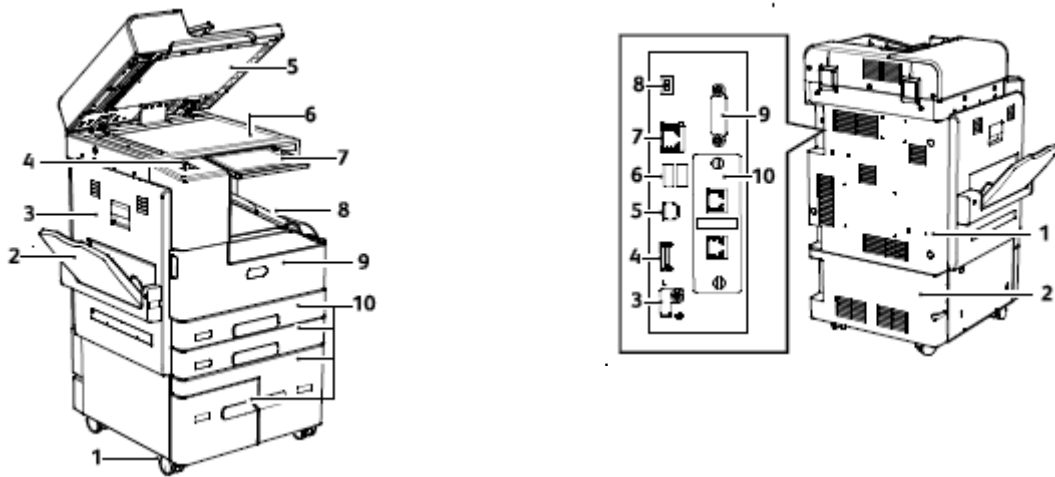

- | | |
|-----------------------|--|
| 1. Locking Caster | 1. Upper Rear Cover |
| 2. Tray 5 | 2. Lower Rear Cover |
| 3. Left Side Door | 3. USB Memory Port, for service only |
| 4. USB Port | 4. USB Memory Card Connections |
| 5. Document Cover | 5. USB Port, Type B |
| 6. Document Glass | 6. USB Ports, Type A |
| 7. Control Panel | 7. Ethernet Connection |
| 8. Center Output Tray | 8. Status Indicator |
| 9. Front Door | 9. Foreign Device Interface (optional) |
| 10. Trays 1-4 | 10. Fax Connections (optional) |

Security Related Interfaces

Security Related Interfaces	
Ethernet	10/100/1000 MB Ethernet interface.
Optional Wi-Fi Dongle	Supports optional 802.11 Dongle.
Rear USB 3.0 (Type B)	USB target connector used for printing. Note: This port can be disabled completely by a system administrator.
Front & Rear USB2.0 (Type A) port(s)	Users may insert a USB thumb drive to print from or store scanned files to. (Physical security of this information is the responsibility of the user or operator.) Note that features that leverage USB ports (such as Scan To USB) can be disabled independently based on services. Firmware upgrades may be applied using this port. Connection of optional equipment such as NFC or CAC readers. Note: This port can be disabled completely by a system administrator.

Encryption and Overwrite

Encryption and Overwrite	
Encryption	AES-256
Media Sanitization	Immediate and On-Demand Image Overwrite.

Controller Non-Volatile Storage

	IC	HDD	SSD	SD Card
	N/A	Required	N/A	Required
Contains User Data (e.g., Print, Scan, Fax)	N/A	Yes	N/A	Yes
Encryption Support	N/A	Configurable	N/A	Always-On
NIST 800-171 Overwrite Support	N/A	Yes	N/A	N/A
Contains Configuration Settings	N/A	Yes	N/A	Yes
Encryption Support	N/A	Configurable	N/A	Always-On
Customer Erasable	N/A	Factory Reset	N/A	Factory Reset

Note: Configuration settings may be erased by the reset to factory defaults feature.

IC- Integrated Circuit, soldered to circuit board

SD Card- Secure Digital Card

HDD- Magnetic Hard Disk Drive

Controller Volatile Memory

Size	Type	Use	User Data	How to Clear	Volatile
4GB	DDR3 DRAM	Executable code, Printer control data, temporary storage of job data	Yes	Power off system	Yes

Additional Information: The controller operating system memory manager allocates memory dynamically between OS, running processes, and temporary data which includes jobs in process. When a job is complete, the memory pages in use are freed and reallocated as required by the OS.

Marking Engine Non-Volatile Storage

N/A. The marking engine does not contain any non-volatile storage.

Marking Engine Volatile Memory

N/A. The marking engine volatile memory does not store or process user data.

AltaLink C8030/C8035/C8045/C8055/C8070

Physical Overview

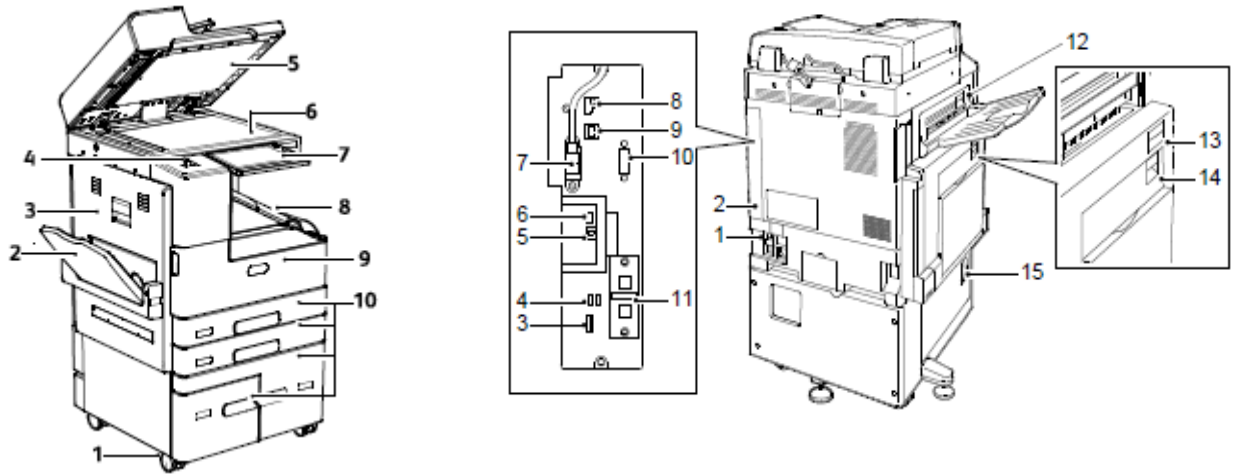

- | | |
|---|---|
| 1. Leveler Foot | 1. Circuit Breaker |
| 2. Tray 5 | 2. Rear Right Cover |
| 3. Left Tray | 3. USB Memory Card Connections and SIM Slot |
| 4. USB Port | 4. USB Port, Type A |
| 5. Document Cover | 5. USB Port, Type B |
| 6. Document Glass | 6. Status Indicator |
| 7. Power/Wake Button | 7. Side 2 Scan Cable |
| 8. Control Panel | 8. Data Port, for service only |
| 9. Center Output Tray | 9. Ethernet Connection |
| 10. Center Bottom Tray | 10. Foreign Device Interface (optional) |
| 11. Main Power Switch behind Front Door | 11. Fax Connections (optional) |
| 12. Trays 1-4 | 12. Door D Release Lever |
| 13. Locking Casters | 13. Door A Release Lever |
| | 14. Door B Release Lever |
| | 15. Door C Release Lever |

Security Related Interfaces

Security Related Interfaces	
Ethernet	10/100/1000 MB Ethernet interface.
Optional Wi-Fi Dongle	Supports optional 802.11 Dongle.
Rear USB 3.0 (Type B)	USB target connector used for printing. Note: This port can be disabled completely by a system administrator.
Front & Rear USB2.0 (Type A) port(s)	Users may insert a USB thumb drive to print from or store scanned files to. (Physical security of this information is the responsibility of the user or operator.) Note that features that leverage USB ports (such as Scan To USB) can be disabled independently based on services.. Firmware upgrades may be applied using this port. Connection of optional equipment such as NFC or CAC readers. Note: This port can be disabled completely by a system administrator.

Encryption and Overwrite

Encryption and Overwrite	
Encryption	AES-256
Media Sanitization	Immediate and On-Demand Image Overwrite.

Controller Non-Volatile Storage

	IC	HDD	SSD	SD Card
	N/A	Required	N/A	Required
Contains User Data (e.g., Print, Scan, Fax)	N/A	Yes	N/A	Yes
Encryption Support	N/A	Configurable	N/A	Always-On
NIST 800-171 Overwrite Support	N/A	Yes	N/A	N/A
Contains Configuration Settings	N/A	Yes	N/A	Yes
Encryption Support	N/A	Configurable	N/A	Always-On
Customer Erasable	N/A	Factory Reset	N/A	Factory Reset

Note: Configuration settings may be erased by the reset to factory defaults feature.

IC- Integrated Circuit, soldered to circuit board

SD Card- Secure Digital Card

HDD- Magnetic Hard Disk Drive

Controller Volatile Memory

Size	Type	Use	User Data	How to Clear	Volatile
4GB	DDR3 DRAM	Executable code, Printer control data, temporary storage of job data	Yes	Power off system	Yes

Additional Information: The controller operating system memory manager allocates memory dynamically between OS, running processes, and temporary data which includes jobs in process. When a job is complete, the memory pages in use are freed and reallocated as required by the OS.

Marking Engine Non-Volatile Storage

N/A. The marking engine does not contain any non-volatile storage.

Marking Engine Volatile Memory

N/A. The marking engine volatile memory does not store or process user data.

10. Appendix B: Security Events

Xerox AltaLink Security Events

ID	Event	Description
1	System startup	Device name Device serial number
2	System shutdown	Device name Device serial number
3	Manual ODIO Standard started	Device name Device serial number
4	Manual ODIO Standard complete	Device name Device serial number Overwrite Status
5	Print job	Job name User Name Completion Status IIO status Accounting User ID Accounting Account ID
6	Network scan job	Job name User Name Completion Status IIO status Accounting User ID Accounting Account ID total-number-net-destination net-destination.
7	Server fax job	Job name User Name Completion Status IIO status Accounting User ID Accounting Account ID Total-fax-recipient-phone-numbers fax-recipient-phone-numbers net-destination.
8	IFAX	Job name User Name Completion Status IIO status Accounting User ID Accounting Account ID total-number-of-smtp-recipients smtp-recipients

ID	Event	Description
9	Email job	Job name User Name Completion Status IIO status Accounting User ID Accounting Account ID total-number-of-smtp-recipients smtp-recipients
10	Audit Log Disabled	Device name Device serial number
11	Audit Log Enabled	Device name Device serial number
12	Copy	Job name User Name Completion Status IIO status Accounting User ID Accounting Account ID Total-fax-recipient-phone-numbers fax-recipient-phone-numbers
13	Efax	Job name User Name Completion Status IIO status Accounting User ID Accounting Account ID Total-fax-recipient-phone-numbers fax-recipient-phone-numbers
14	Lan Fax Job	Job name User Name Completion Status IIO status Accounting User ID Accounting Account ID Total-fax-recipient-phone-numbers fax-recipient-phone-numbers
15	Data Encryption enabled	Device name Device serial number
16	Manual ODIO Full started	Device name Device serial number
17	Manual ODIO Full complete	Device name Device serial number Overwrite Status
18	Data Encryption disabled	Device name Device serial number

ID	Event	Description
20	Scan to Mailbox job	Job name or Dir name User Name Completion Status IIO status
21	Delete File/Dir	Job name or Dir name User Name Completion Status IIO status
23	Scan to Home	UserName Device name Device serial number Completion Status (Enabled/Disabled)
24	Scan to Home job	Job name or Dir name User Name Completion Status (Normal/Error) IIO status Accounting User ID-Name Accounting Account ID-Name total-number-net-destination net-destination
25	Copy store job	Job name or Dir name User Name Completion Status (Normal/Error) IIO status
26	PagePack login	Device name Device serial number Completion Status: Success: (if Passcode is ok) Failed: (if Passcode is not ok) Locked out (if Max Attempts Exceed 5) Time Remaining: Hrs (Remaining for next attempt) Min (Remaining for next attempt)
27	Postscript Passwords	Device name Device serial number StartupMode (enabled/disabled) System Params Password changed Start Job Password changed
29	Network User Login	UserName Device name Device serial number Completion Status (Success, Failed)
30	SA login	UserName Device name Device serial number Completion Status (Success or Failed)

ID	Event	Description
31	User Login	UserName Device name Device serial number Completion Status (Success or Failed)
32	Service Login	Service name Device name Device serial number Completion status (Success or Failed).
33	Audit log download	UserName Device name Device Serial Number Completion status (Success or Failed).
34	IIO feature status	UserName Device name Device serial number IIO Status (enabled or disabled)
35	SA pin changed	UserName Device name Device serial number Completion status
36	Audit log Saved	UserName Device name Device serial number Completion status
37	SSL	UserName Device name Device serial number Completion Status (Enabled/Disabled/Terminated)
38	X509 certificate	UserName Device name Device serial number Completion Status (Created/uploaded/Downloaded).
39	IP sec Enable/Disable/Configure	UserName Device name Device serial number Completion Status (Configured/enabled/disabled/Terminated)
40	SNMPv3	UserName Device name Device serial number Completion Status (Configured/enabled/disabled).
41	IP Filtering Rules	UserName Device name Device serial number Completion Status (Configured/enabled/disabled).
42	Network Authentication Enable/Disable/Configure	UserName Device name Device serial number Completion Status (Enabled/Disabled)

ID	Event	Description
43	Device clock	UserName Device name Device serial number Completion Status (time changed/date changed)
44	SW upgrade	Device name Device serial number Completion Status (Success, Failed)
45	Cloning	Device name Device serial number Completion Status (Success, Failed)
46	Scan Metadata Validation	Device name Device serial number Completion Status (Metadata Validation Success or Failed)
47	Xerox Secure Access Enable/Disable/Configure	Device name Device serial number Completion status (Configured/enabled/disabled)
48	Service login copy mode	Service name Device name Device serial number Completion Status (Success, Failed)
49	Smartcard (CAC/PIV) access	UserName (if valid Card and Password are entered) Device name Device serial number Process Name
50	Process terminated	Device name Device serial number Process name
51	ODIO scheduled	Device name Device serial number ODIO type (Full or Standard) Scheduled time ODIO status (Started/Completed/canceled) Completion Status (Success/Failed/Canceled)
53	CPSR Backup	File Name User Name Completion Status (Normal / Error) IIO Status
54	CPSR Restore	File Name User Name Completion Status (Normal / Error) IIO Status
55	SA Tools Access Admin	Device serial number Completion Status (Locked/Unlocked)
57	Session Timer Logout	Device Name Device Serial Number Interface (Web, LUI) User Name (who was logged out) Session IP (if available)

ID	Event	Description
58	Session Timer Interval Change	Device Name Device Serial Number Interface (Web, LUI)(Timer affected by change) User Name (who made this change) Session IP (if available) Completion Status
59	Feature Access Control Enable/Disable/Configure	User Name Device Name Device Serial Number Completion Status (Enabled/Disabled/Configured) Interface (Web, Local, CAC, SNMP) Session IP address (if available)
60	Device Clock NTP Enable/Disable	Device Name Device serial number Enable/Disable NTP NTP Server IP Address Completion Status (Success/Failed)
61	Grant / Revoke Admin	Device Name Device Serial Number User Name (of target user) Grant or Revoke (the admin right) Completion Status (Success/Failed)
62	Smartcard (CAC/PIV) Enable/Disable/Configure	UserName Device Name Device Serial Number Completion Status (Success/Failed)
63	IPv6 Enable/Disable/Configure	UserName Device Name Device Serial Number Completion Status (Success/Failed)
64	802.1x Enable/Disable/Configure	UserName Device Name Device Serial Number Completion Status (Success/Failed)
65	Abnormal System Termination	Device Name Device Serial Number
66	Local Authentication	UserName Device Name Device Serial Number Completion Status (Enabled/Disabled)
67	Web User Interface Authentication (Enable Network or Local)	UserName Device Name Device Serial Number Authentication Method Enabled (Network/Local)
68	FIPS Mode Enable/Disable/Configure	UserName Device name Device Serial Number Enable/Disable/Configure
69	Xerox Secure Access Login	UserName Device Name Device Serial Number Completion Status (Success/Failed)

ID	Event	Description
70	Print from USB Enable/Disable	User Name Device Name Device Serial Number Completion Status (Enabled/Disabled)
71	USB Port Enable/Disable	User Name Device Name Device Serial Number USB Port (Front/Rear) Completion Status (Enabled/Disabled)
72	Scan to USB Enable/Disable	User Name Device Name Device Serial Number Completion Status (Enabled/Disabled)
73	System Log Download	Username IP of requesting device (if available) File names downloaded Destination (IP address or USB device) Completion status (Success/failed)
74	Scan to USB Job	Job Name User Name Completion Status IIO Status Accounting User ID-Name Accounting Account ID-Name
75	Remote UI feature	User Name Device Name Device Serial Number Completion Status (Enabled/Disabled/Configured)
76	Remote UI session	User Name Device Name Device Serial Number Completion Status (Initiated/Terminated) Remote Client IP Address
77	Remote Scan Feature Enable/Disable (TWAIN driver)	User Name Device Name Device Serial Number Completion Status (Enable/Disable)
78	Remote Scan Job Submitted (TWAIN driver)	UserName (at client if available) IP address of submitting client Device name Device serial number Job name (if accepted) Completion status (accept/reject request)
79	Scan to Web Service Job (Remote Scan Job Completed) (TWAIN driver)	Job name UserName Accounting User ID-Name Accounting Account ID-Name Completion status Destination

ID	Event	Description
80	SMTP Connection Encryption	UserName Device name Device serial number Completion Status (Enabled for STARTTLS / Enabled for STARTTLS if Avail / Enabled for SSL/TLS / Disabled)
81	Email Domain Filtering Rule	User name Device Name Device Serial Number Completion Status (Feature Enabled/Feature Disabled, Rule Added / Rule Deleted)
82	Software Self Test Started	Device Name Device Serial Number
83	Software Self Test Complete	Device Name Device Serial Number Completion Status(Success/Failed/Cancelled)
84	McAfee Security State	UserName Device name Device serial number Security Mode (Enhanced Security / Integrity Control) Completion Status (Enabled / Disabled / Pending)
85	McAfee Security Event	Device name Device serial number Type (Read / Modify / Execute / Deluge) McAfee message text
87	McAfee Agent	User name Device name Device serial number Completion Status (Enabled / Disabled)
88	Digital Certificate Import Failure	Device name
89	User Name Add/Delete	Device serial number
90	User Name Password Change	Security Mode
91	EFax Job Secure Print Passcode	UserName (managing passcodes) Device name Device serial number Completion Status (Passcode Created/Changed)
92	Scan2Mailbox Folder Password Change	UserName (managing passwords) Device name Device serial number Folder Name Completion Status (Password was Changed)

ID	Event	Description
93	EFax Mailbox Passcode	UserName (managing passcodes) Device name Device serial number Completion Status (Passcode Created/Changed)
94	FTP/SFTP Filing Passive Mode	User Name Device Name Device Serial Number Completion Status (Enabled / Disabled)
95	EFax Forwarding Rule	User Name Device Name Device Serial Number Fax Line 1 or 2 (if applicable) Completion Status (Rule Edit / Rule Enabled / Rule Disabled)
96	EIP Weblets Allow Install	UserName Device name Device serial number Completion Status (Enable Installation / Block Installation)
97	EIP Weblets Install	UserName Device name Device serial number Weblet Name Action (Install / Delete) Completion (Success / Fail)
98	EIP Weblets Enable / Disable	UserName Device name Device serial number Weblet Name Completion Status (Enable / Disable)
99	Network Connectivity Enable / Disable	UserName Device name Device serial number Completion Status (Enable Wireless / Disable Wireless (Enable Wired /Disable Wired)
100	Address Book Permissions	UserName Machine Name Machine serial number Completion Status (SA Only/Open Access Enabled WebUI) / (SA Only/Open Access Enabled LocalUI)
101	Address Book Export	UserName Machine Name Machine serial number
102	SW upgrade enable / disable	UserName Device name Device serial number Completion Status (Enable Installation / Disable Installation)

ID	Event	Description
103	Supplies Plan Activation	Device name Device serial number Completion Status: Success: (if Passcode is ok) Failed: (if Passcode is not ok) Locked out (if Max Attempts Exceed 5) Time Remaining : Hrs (Remaining for next attempt) Min (Remaining for next attempt)
104	Plan Conversion	Device name Device serial number Completion Status: Success: (if Passcode is ok) Failed: (if Passcode is not ok) Locked out (if Max Attempts Exceed 5) Time Remaining : Hrs (Remaining for next attempt) Min (Remaining for next attempt)
105	IPv4 Enable/Disable/Configure	UserName Device name Device serial number Completion Status (Enabled Wireless/Disabled Wireless/ Configured Wireless) (Enabled Wired/Disabled Wired/ Configured Wired)
106	SA PIN Reset	Device serial number Completion Status (Success/Failed)
107	Convenience Authentication Login	UserName Device name Device serial number Completion Status (Success or Failed)
108	Convenience Authentication Enable/Disable/Configure	UserName Device name Device serial number Completion Status (Enabled/Disabled/Configured)
109	Efax Passcode Length	UserName (managing passcodes) Device name Device serial number Completion Status (Passcode Length Changed)
110	Custom Authentication Login	UserName Device name Device serial number Completion Status (Success or Failed)
111	Custom Authentication Enable/Disable/Configure	UserName Device name Device serial number Completion Status (Enabled/Disabled/Configured)

ID	Event	Description
112	Billing Impression Mode	UserName Device name Device serial number Mode Set to (A4 Mode, A3 Mode Completion Status (Success, Failed Impression data
113	Airprint Enable/Disable/Configure	UserName Device name Device serial number Completion Status (Enabled/Disabled/Configured)
114	Device cloning enable / disable	UserName Device name Device serial number Completion Status Enable / Disable
115	Save for reprint job	UserName Device name Device serial number Completion Status (Standard Access, Open Access, Restricted)
116	Web UI Access/Configure	UserName Device name Device serial number Completion Status (Standard Access, Open Access, Restricted)
117	System log push to Xerox	Username if authenticated Server destination URL Log identifier string (filename) Completion Status (Success / Failed)
119	Scan to WebDAV Job	Job name User Name Completion Status IIO status Accounting User ID-Name Accounting Account ID-Name WebDAV destination.
120	Mopria Print enable / disable	UserName Device name Device serial number Completion Status Enable / Disable
121	PoS credit card API enable / disable	UserName Device name Device serial number Completion Status Enable / Disable

ID	Event	Description
122	PoS CC data transfer data transfer	Job name or number? Machine Name Machine serial number Destination server Completion status (Success / Fail)
124	Invalid Login Attempt Lockout	Device name Device serial number Interface (Web UI, Local UI) Session IP Address if available
125	Protocol audit Log enable/Disable	UserName Device Name Device serial number Completion Status Enable / Disable
126	Display Device information configure	UserName Device Name Device serial number Completion Status (Configured)
127	Invalid Login Lockout Expires	Device name Device serial number Interface (Web UI) Session IP Address if available Count of invalid attempts: "attempts xx" where xx = the number of attempts.
128	Erase Customer Data	Erase Customer Data Device serial number Success / Failed
129	Audit log SFTP scheduled Configure	UserName Device Name Device serial number Completion status (Enable/Disable/Configured)
130	Audit Log SFTP Transfer	UserName Device Name Device serial number Destination server Completion Status (File Transmitted)
131	Remote Software Download Enable Disable	UserName Device name Device serial number Completion Status (Enable/Disable)
132	Airprint & Mopria Scanning Enable/Disable/Configure	UserName Device Name Device serial number Completion Status (Enable/Disable/Configured)

ID	Event	Description
133	Airprint & Mopria Scan Job Submitted	Job name (if accepted) UserName (if available) IP address of submitting client Device name Device serial number Completion status (accept/reject request)
134	Airprint & Mopria Scan Job Completed	Job name UserName (if available) Completion status
136	Remote Services NVM Write	Device Name Device Serial Completion Status (Success-Fail)
137	Remote Services FIK Install	Device Name Device Serial Completion Status (Success-Fail) User-readable names for the features being installed
138	Remote Services Data Push	Device Name Device Serial Completion Status (Success-Fail)
139	Remote Services	User Name, Device Name, Device Serial Status: ("Enabled" / "Disabled")
140	Restore enable/disable	User Name Device name Device serial number Completion status Enable / Disable
141	Backup-Restore file downloaded	File Name User Name Interface (WebUI) IP Address of the destination (if applicable) Completion Status (Success or Failed)
142	Backup-Restore restore installed	File Name User name Device name Device IP address Interface (WebUI) Completion Status (Success or Failed)
143	Google Cloud Services	User name Device name Device serial number Completion Status-(Enabled / Disabled / Configured)
144	User or Group Role Assignment	User name Device name Device serial number User or group name (assigned) Role name Action (added/removed)

ID	Event	Description
145	User Permission Role	User name Device name Device serial number Role name Completion status (Created / Deleted / Configured)
146	Admin Password Policy Configure	User name Device name Device serial number
147	Local user account password policy	User name Device name Device serial number
148	Restricted admin login	User name Device name Device serial number Completion status: "Success" or "Failed"
149	Grant / revoke restricted admin rights	User name (of user making the change) Device name Device serial number User name (of target user) Action: "Grant" or "Revoke"
150	Manual session logout	Device Name Device Serial Number Interface (Web, LUI, CAC) User Name (who was logged out) Session IP (if available)
151	IPP Enable/Disable/Configure	User name Device name Device serial number Completion status: ("Enabled" / "Disabled" / "Configured")
152	HTTP Proxy Server Enable/Disable/Configure	User name Device name Device serial number Completion status: ("Enabled" / "Disabled" / "Configured")
153	Remote Services Software Download	Device Name Device Serial number File Name
154	Restricted Admin Permission Role	User name Device name Device serial number Restricted admin role name Completion status (Created / Deleted / Configured)
155	EIP Weblet Installation Security Policy	User name Device name Device serial number Policy: ("allow installation of encrypted Weblets" / " allow installation of both encrypted and unencrypted Weblets")
159	Send Engineering Logs on Data Push	User name (if available) Device name Device serial number Current setting ("Enabled" / "Disabled")

ID	Event	Description
160	Allow the Print Submission of Clone Files	UserName (if available) Device name Device serial number Completion status: ("Enabled" / "Disabled")
161	Network Troubleshooting Start, Stop	User name Device Name Device Serial Number Completion Status ("Started", "Stopped")
162	Network Troubleshooting Data Download	User name File name (of downloaded file) Device Name Device Serial Number Destination (IP address) Completion Status ("Success" / "Failed")
163	dns-sd text file download	User name File name (of downloaded file) Device Name Device Serial Number Destination (IP address) Completion Status ("Success" / "Failed")
164	One-Touch App Management	User Name Device name Device serial number Onetouch application Display Name Action ("Install" / "Un-install") Completion: ("Success" / "Failed")
165	SMB Browse	User name Device name Device serial number Completion status: ("Enabled" / "Disabled" / "Configured")
166	Job Data Removal Standard started	Device name Device serial number
167	Job Data Removal Standard complete	Device name Device serial number Completion Status ("Success" / "Failed")
168	Job Data Removal Full started	Device name Device serial number
169	Job Data Removal Full complete	Device name Device serial number Completion Status ("Success" / "Failed")
170	Scheduled Job Data Removal Configure	User Name Device name Device serial number Status ("Enable"/"Disable"/"Configured")
171	Cross-Origin-Resource-Sharing (CORS)	User Name Device name Device serial number Status ("Enable"/"Disable")

ID	Event	Description
172	One-Touch App Export	User name Device name Device serial number Completion Status: ("Success" "Failed")
173	Device File Distribution Trust Operations	User name Device name Device serial number Member name Member serial number TC Lead Device Name TC Lead Serial Number Trust operation: ("Grant" "Revoke") Completion status: ("Success" "Failed")
174	Device File Distribution Feature	User name Device name Device serial number Trust operation: ("Enable" "Disable" "Configure") Completion status: ("Success" "Failed")
175	Device File Distribution - Store File for Distribution	User name Device name Device serial number File type: ("SWUP" "Clone" "Add-On") File name
176	Xerox Configuration Watchdog	User name Device Name Device Serial number Completion status: ("Enabled" "Disabled")
177	Xerox Configuration Watchdog Check Complete	User name (if available. "SYSTEM", if executed as a scheduled event) Device name Device serial number Completion status ("Success" "Failed")
178	Xerox Configuration Watchdog Remediation Complete	User name (if available. "SYSTEM", if executed as a scheduled event) Device name Device serial number Completion status ("Success" "Failed")
179	ThinPrint Feature	User Name Device name Device serial number Completion Status: ("Enabled" "Disabled" "Configured")
181	Network Troubleshooting Install, Uninstall	User Name Device name Device serial number Completion Status: ("Installed" "Uninstalled")

ID	Event	Description
182	POP3 Connection Encryption (TLS)	User Name Device name Device serial number Completion Status: ("Enabled" "Disabled" "Configured")