

# Security Guide

Xerox® AltaLink® B8245/B8255/B8270 Multifunction Printer

Xerox® AltaLink® C8230/C8235/C8245/C8255/C8270 Color Multifunction Printer

Version 1.0

May 2024



**xerox**<sup>™</sup>

©2024 Xerox Corporation. All rights reserved.

Xerox®, CentreWare®, AltaLink®, Xerox Extensible Interface Platform® are trademarks of Xerox Corporation in the United States and/or other countries. BR38616

Adobe, Adobe PDF logo, Acrobat, and PostScript are either registered trademarks or trademarks of Adobe in the United States and/or other countries.

Android, Google Play, Google Drive and Google Chrome are trademarks of Google LLC.

Apache® is a trademark of the Apache Software Foundation in the United States and/or other countries.

Apple, App Store, AirPrint, Bonjour, iBeacon, iPad, iPhone, iPod, iPod touch, Mac, Macintosh, macOS, and OS X are trademarks of Apple, Inc., registered in the U.S. and other countries and regions.

The Bluetooth® word mark is a registered trademark owned by Bluetooth SIG, Inc. and any use of such marks by Xerox is under license.

Cisco®, Cisco TrustSec®, and IOS® are registered trademarks of Cisco Systems, Inc. and/or its affiliates in the United States and certain other countries.

DROPBOX and the Dropbox Logo are trademarks of Dropbox, Inc.

Intel is a trademark of Intel Corporation or its subsidiaries in the United States and other countries.

Kerberos is a trademark of the Massachusetts Institute of Technology (MIT).

Linux® is the registered trademark of Linus Torvalds in the U.S. and other countries.

Microsoft, Active Directory, Azure, Office 365, OneDrive, Windows are trademarks of the Microsoft group of companies.

Mopria™ is a registered and/or unregistered trademark of Mopria Alliance, Inc. in the United States and other countries. Unauthorized use is strictly prohibited.

ThinPrint is a registered trademark of Cortado AG in the United States and other countries.

Trellix, ePolicy Orchestrator, and ePO are trademarks Musarubra US LLC.

Wi-Fi® is a registered trademark of Wi-Fi Alliance®.

Wi-Fi Protected Setup™, WPA™, WPA2™, and WPA3™ are trademarks of Wi-Fi Alliance®.

Document Version: 1 (July 2024).

# Contents

- 1. Introduction.....5**
  - Purpose.....5
  - Target Audience.....5
  - Disclaimer.....5
  
- 2. Product Description.....6**
  - Controller External Interfaces.....8
  - Optional Equipment.....9
  
- 3. User Data Protection.....10**
  - User Data Protection While Within Product .....10
  - User Data in Transit .....11
  
- 4. Network Security.....15**
  - TCP/IP Ports and Services .....15
  - Network Encryption .....17
  - Public Key Infrastructure (PKI).....20
  - Network Access Control.....23
  - Additional Network Security Controls.....26
  
- 5. Device Security: UEFI, Firmware, OS, Runtime, and Operational Security Controls .....27**
  - Pre-Boot Security .....27
  - Boot Process Security.....27
  - Runtime Security .....29
  - Event Monitoring and Logging .....29
  - Operational Security.....30
  
- 6. Configuration and Security Policy Management Solutions.....32**
  
- 7. Identification, Authentication, and Authorization.....34**
  - Authentication.....34
  - Authorization (Role-Based Access Controls).....37
  
- 8. Additional Information and Resources .....39**
  - Security @ Xerox® .....39
  - Responses to Known Vulnerabilities .....39
  - Additional Resources .....39

<b>9.</b>	<b>Appendix A: Product Security Profiles.....</b>	<b>40</b>
	AltaLink® B8145/B8155/B8170/B8200 & C8130/C8135/C8145/C8155/C8170/C8200 .....	40
<b>10.</b>	<b>Appendix B: Security Events.....</b>	<b>43</b>
	AltaLink® Security Events .....	43

# 1. Introduction

## Purpose

The purpose of this document is to disclose information for the AltaLink® multifunction devices (hereinafter called as “the product” or “the system”) with respect to product security. Product Security, for this paper, is defined as how image data is stored and transmitted, how the product behaves in a network environment, and how the product may be accessed both locally and remotely. The purpose of this document is to inform Xerox customers of the design, functions, and features of the product with respect to Information Assurance. This document does not provide tutorial level information about security, connectivity, or the product’s features and functions. This information is readily available elsewhere. We assume that the reader has a working knowledge of these types of topics.

## Target Audience

The target audience for this document is Xerox field personnel and customers concerned with IT security.

## Disclaimer

The content of this document is provided for information purposes only. The performance of the products referenced herein is exclusively subject to the applicable Xerox Corporation terms and conditions of sale and/or lease. Nothing stated in this document constitutes the establishment of any additional agreement or binding obligations between Xerox Corporation and any third party.

## 2. Product Description

### PHYSICAL COMPONENTS

Xerox® AltaLink® B8245/B8255/B8270 Multifunction Printer and C8230/C8235/C8245/C8255/C8270 Color Multifunction Printer are very similar and consist of an input document handler and scanner, marking engine, controller, and user interface. A typical configuration is depicted below. Please note that options including finishers, paper trays, document handlers, etc. may vary in configuration, however, configurations are not relevant to security and are not discussed.

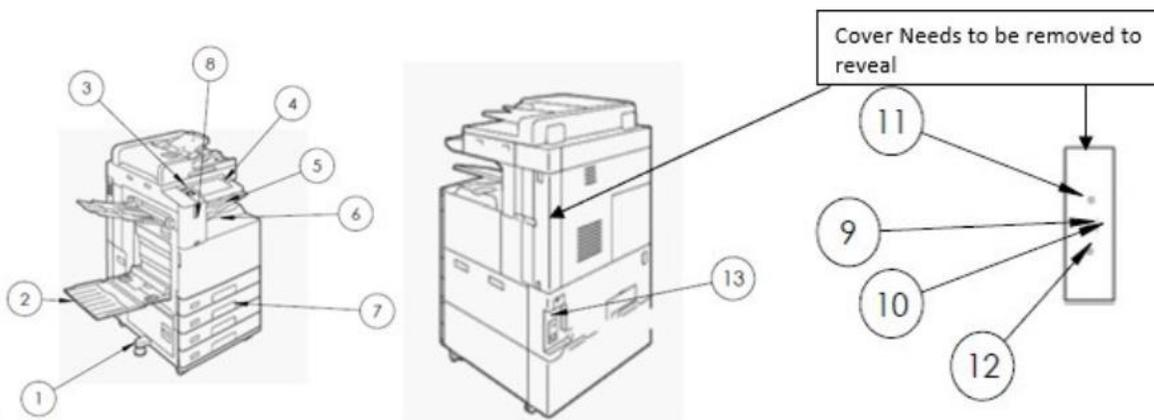

- |                                 |  |
|---------------------------------|--|
| 1. Stabilizer                   | 8. Smart Proximity Sensor.                               |
| 2. Bypass paper feed tray.      | 9. Rear USB Port(s)*                                     |
| 3. Front USB Port(s)*           | 10. Wireless Network Adapter with Bluetooth*             |
| 4. Touch screen user interface. | 11. RJ45 Ethernet connection*                            |
| 5. Upper paper tray.            | 12. Service port<br>(May require disassembly to access). |
| 6. Lower paper tray.            | 13. AC Power   |
| 7. Paper feed trays.            | 14. *Denotes a security related component                |

## ARCHITECTURE

AltaLink® products share a common architecture which is depicted below. The following sections describe components in detail.

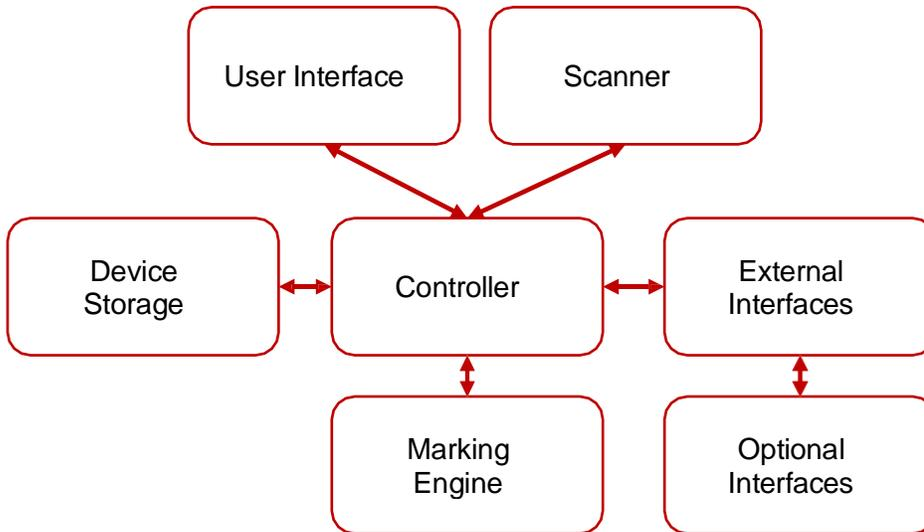

## USER INTERFACE

The user interface detects soft and hard button actuations and provides text and graphical prompts to the user. The user interface is sometimes referred to as the Graphical User Interface (GUI) or Local User Interface (LUI) to distinguish it from the remote web server interface, also known as Embedded Web Server (EWS) or WebUI.

The user interface allows users to access product services and functions. Users with administrative privileges can manage the product configuration settings. User permissions are configurable through Role-Based Access Control (RBAC) policies, described in Section 7 Identification, Authentication, and Authorization.

## SCANNER

The scanner converts documents from hardcopy to electronic data. The document handler moves originals into a position to be scanned. The scanner provides enough image processing for signal conditioning and formatting. The scanner does not store scanned images.

## MARKING ENGINE

The Marking Engine performs copy/print paper feeding and transport, image marking, fusing, and document finishing. The marking engine is comprised of paper supply trays and feeders, paper transport, LED scanner, xerographics, and paper output and finishing. The marking engine is only

accessible to the Controller via inter-chip communication with no other access and does not store user data.

## **CONTROLLER**

The controller manages document processing using proprietary hardware and algorithms to process documents into high-quality electronic and/or printed reproductions. Documents may be temporarily buffered in RAM during processing. Standard models are equipped with a 256 GB Solid-State Drive (SSD). An optional 1 TB NVMe SSD is also available. For model-specific details please see Appendix A: Product Security Profiles.

In addition to managing document processing, the controller manages all network functions and services. Details can be found in the Network Security section.

The controller handles all I/O communications with connected products. The following section describes each interface. Please note that not all interfaces are supported on all models; details about each model can be found in Appendix A: Product Security Profiles.

## **Controller External Interfaces**

### **USB Type A (Front and Rear) and Type B (Rear Only) PORT(S)**

One or more USB ports may be on the front or rear of the product. Front and rear type A ports may be enabled or disabled by a system administrator. The USB ports support the following:

- Walk-up users may insert a USB thumb drive to store or retrieve documents for scanning and/or printing from a FAT or licensable exFAT formatted USB device. The controller will only allow reading/writing of a limited set of known document types (such as, PDF, PNG, JPEG, TIFF, etc.). Other file types including binary executables are not supported.

Note: Features that use the USB ports (such as Scan To USB) can be disabled independently.

- Connection of optional equipment such as Bluetooth/Wireless (rear ports), or CAC readers.
- Firmware updates may be submitted through USB ports. Note that the product must be configured to allow local firmware updates, or the update will not be processed.
- There are 2 USB ports in the front of the engine and 2 USB 3.0 and 1 USB 2.0 port in the rear of the engine.

### **10/100/1000 MB ETHERNET TIA-568 NETWORK CONNECTOR**

This is a standard Ethernet network connector and conforms to IEEE Ethernet 802.3 standards.

## Optional Equipment

### **RJ-11 ANALOG FAX AND TELEPHONE**

The embedded Fax service uses the installed embedded fax card to send and receive images over the telephone interface. The Fax card plugs into a custom interface slot on the controller. The Fax telephone lines are connected directly to the Fax card via RJ-11 connectors, and it uses T.30 Fax Modem protocol and will not accept data or voice communication. All remaining Fax-specific features are implemented in software on the controller.

### **WIRELESS NETWORK ADAPTER WITH BLUETOOTH**

AltaLink® B8245/B8255/B8270 Multifunction Printer and C8230/C8235/C8245/C8255/C8270 Color Multifunction Printer products accept an optional wireless and Bluetooth combined solution that can be installed in the rear USB port. This solution can support dual band Wi-Fi, Wi-Fi Direct, and iBeacon for AirPrint Discovery.

When iBeacon is enabled and configured, it enables the Xerox® AltaLink® product to advertise basic printer discovery information, including a routable IP address, via the Bluetooth Low Energy Beacon. There is no user data transfer over Bluetooth. iBeacon functionality can be disabled using the embedded web server of the product.

### **NEAR FIELD COMMUNICATIONS (NFC) READER**

AltaLink® products come standard with an NFC Chip built into the front panel. This is only read from an NFC client. The data exchanged is not encrypted and may include information including system network status, IP address and product location. NFC functionality can be disabled using the embedded web server of the product. NFC functionality requires a software plugin that can be obtained from Xerox sales and support.

Information shared over NFC includes: IPv4 Address, IPv6 Address, MAC Address, UUID (a unique identifier on the NFC client), and Fully Qualified Domain Name.

### **SMARTCARD – CAC/PIV**

AltaLink® products support a variety of smart cards that can be used to log in to the machine. Please contact Xerox Support for a list of supported cards and card readers.

### **FOREIGN PRODUCT INTERFACE**

This port is used to connect optional equipment to control access to the machine. A typical application is a coin-operated product where a user must deposit money to enable the machine to print. The information available via the Foreign Product Interface is limited to optically isolated pulses that can be used to count impressions marked on hardcopy sheets. No user data is transmitted to or from this interface.

## 3. User Data Protection

Xerox printers and multifunction products receive, process, and may optionally store user data from several sources including local print, scan, fax, or copy jobs or mobile and cloud applications, etc. Xerox products protect user data being processed by employing strong encryption. The standard configuration is sold with SSD.

### User Data Protection While Within Product

This section describes security controls that protect user data while it is resident within the product. For a description of security controls that protect data in transit, please refer to the following section that discusses data in transit; also, the Network Security section of this document.

#### **ENCRYPTION**

All user data being processed or stored to the product is encrypted by default. Encryption cannot be disabled on this family of products.

#### **PRIVATE KEY MANAGEMENT**

The disk encryption Private key on the system is managed in compliance with NIST Special Publication 800-57 *Recommendation for Key Management*. This includes keying material in transition and at rest and is managed by the TPM Software module embedded in the controller chip.

#### **JOB DATA REMOVAL AVAILABLE ON STANDARD SSD CONFIGURATION**

The Xerox® AltaLink B82xx and C82xx device administrator can also initiate a feature called 'Job Data Removal', accessible via the local or web user interface, 'on demand', or on a 'scheduled' basis. When initiated, this feature can delete both temporary files (associated with normal print, scan fax operations) using the 'standard' setting, or temporary files and files specifically stored for later use by the user (e.g. Print with Saved Job type, Scan to Mailbox, Fax Mailbox, etc.)

## User Data in Transit

This section focuses on the protection of user data (print/scan/other jobs) in transit as they are submitted to the product for processing and/or are sent from the product to other systems. Additional protections are also discussed in the Network Security section of this document.

### INBOUND USER DATA (PRINT JOB SUBMISSION)

In addition to supporting network level encryption including IPsec and WPA, Xerox products also support encryption of print job data at the time of submission. This can be used to securely transmit print jobs over unencrypted connections or to enhance existing network level security controls.

Encrypted Transport	Description
IPPS (TLS)	Submit print jobs via Secure Internet Printing Protocol. This protocol is based on HTTP and utilizes the TLS suite to encrypt data.
HTTPS (TLS)	Securely submit a print job directly to product via the built-in web server.
Xerox Print Stream Encryption	The Xerox Global Print Driver® supports document encryption for any print jobs to enabled products. Simply configure Document Encryption to On in the Advanced tab of the print driver at print time.

### EMAIL SIGNING AND ENCRYPTION USING S/MIME

S/MIME (Secure/Multipurpose Internet Mail Extensions) provides Authentication, Message integrity, Non-repudiation, and encryption of email.

**AltaLink® B8245/B8255/B8270 Multifunction Printer**  
**AltaLink® C8230/C8235/C8245/C8255/C8270 Color Multifunction Printer**

Email S/MIME		
	Versions	v3
	Digest	SHA1, SHA256, SHA384, SHA512
	Encryption	AES128, AES192, AES256

**SCANNING TO NETWORK REPOSITORY EMAIL FAX SERVER (OUTBOUND USER DATA)**

AltaLink® multifunction products support scanning of hardcopy documents to external network locations including file repositories and email and facsimile services. In addition to supporting network level encryption including IPsec, Xerox products support the following.

Protocol	Encryption	Description
HTTP	N/A	Unencrypted HTTP protocol
HTTPS (TLS)	TLS	HTTP encrypted by TLS
FTP	N/A	Unencrypted FTP
SFTP (SSH)	SSH	FTP encrypted by SSH
SMBv3	Yes	Encryption may be enabled on a Windows share
SMBv2	N/A	Supported and configurable
SMBv1	N/A	Supported and configurable
SMTP (email)	S/MIME	The product uses SMTP to transmit data to the email server. Email authentication, encryption, and signing are supported. Please refer to the Network Security section of this document for details.

**SCANNING TO USER LOCAL USB STORAGE PRODUCT (OUTBOUND USER DATA)**

Scan data is transferred directly to the user’s USB product. Filesystem encryption of user products is not supported.

NOTE: TLS 1.0 and 1.1 are deprecated and considered insecure. Xerox recommends using TLS 1.2 or higher.

<b>AltaLink® B8245/B8255/B8270 Multifunction Printer</b> <b>AltaLink® C8230/C8235/C8245/C8255/C8270 Color Multifunction Printer</b>	
<b>Local Data Encryption</b>	AES-256
Federal Information Protection Standard 140-3	Yes
Device Sanitization (removes all customer identifiable information on demand)	Supported
<b>Print Submission</b>	
IPPS (TLS)	Supported
HTTPS (TLS)	Supported

**AltaLink® B8245/B8255/B8270 Multifunction Printer**  
**AltaLink® C8230/C8235/C8245/C8255/C8270 Color Multifunction Printer**

Xerox Print Stream Encryption	Supported
<b>Scan to Repository Server</b>	
HTTPS (TLS)	1.0, 1.1, 1.2, 1.3
SFTP (SSH)	SSH-2
SMB (unencrypted)	v1, v2
SMB (with share encryption enabled)	v3
HTTP (unencrypted)	Supported
FTP (unencrypted)	Supported
<b>Scan to Fax Server</b>	
HTTPS (TLS)	1.0, 1.1, 1.2
SFTP (SSH)	SSH-2
SMB (unencrypted)	v1, v2
SMB (with share encryption enabled)	v3 (Dialect 3.00, 3.02, 3.1.1)
S/MIME	Supported
HTTP (unencrypted)	Supported
FTP (unencrypted)	Supported
SMTP (unencrypted)	Supported
<b>Scan to Email</b>	
S/MIME	Supported
SMTP (unencrypted)	Supported
TLS (StartTLS)	Supported

**ADD ON APPS – CLOUD, GOOGLE, DROPBOX, AND OTHERS (OUTBOUND USER DATA)**

The Xerox® App Gallery contains several additional applications that extend the capabilities of Xerox products. Discussion of App security is beyond the scope of this document. Xerox Apps utilize the security framework provided by the third-party vendor. (For example, Microsoft O365 or Google Apps would utilize Microsoft and Google’s security mechanisms respectively). Please consult documentation for individual Apps and third-party security for details.

**NATIVE SCAN AND PRINT – DROPBOX, MICROSOFT ONEDRIVE (INBOUND AND OUTBOUND USER DATA)**

With the rise of hybrid working, and workers splitting their time between their home and office maximizing productivity has never been more important. Which means it is essential to have access to the same set of productivity tools no matter where you choose to work from.

Say hello to hassle-free scanning and printing right from your desktop or laptop without the complicated setup. The Xerox® Print and Scan Experience App simplifies everything from getting connected, to taking advantage of the most advanced features.

**EMBEDDED AI-ASSISTED INBOX APPS – SUMMARIZER, XEROX® AUTO-REDACT, NOTE CONVERTER (OUT BOUND USER DATA)**

For more detailed information, please consult documentation for [individual Apps](#).

- [Summarizer](#)
- [Auto-Redact](#)
- [Note Converter](#)

## 4. Network Security

Xerox products are designed to offer a high degree of security and flexibility in almost any network environment. This section describes several aspects of the product related to network security.

### TCP/IP Ports and Services

Xerox devices are robust, offering support for a wide array of services and protocols. The devices can host services and act as a client for others. The diagram below presents a high-level overview of inbound communications (from other hosts on the network into listening services on the device) and outbound connections initiated by the device (acting as a client to external network services).

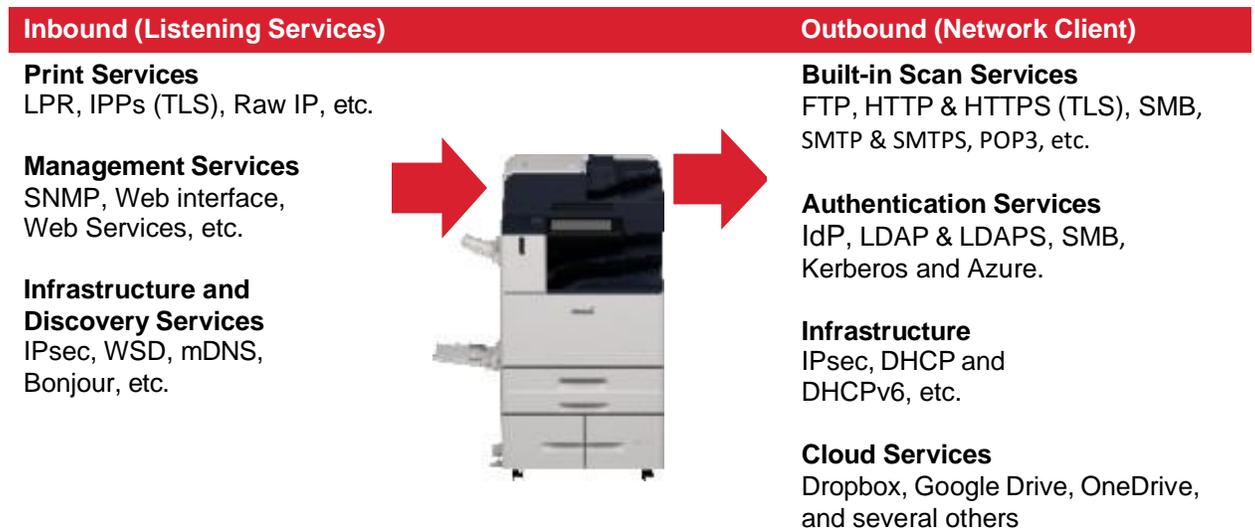

**LISTENING SERVICES (INBOUND PORTS)**

The following table summarizes all potentially open ports on the product. These ports can be enabled/disabled within the product configuration. Some ports can be configured to a different value for some features/protocols.

Port	Type	Service Name
80 or 443	TCP	HTTP including Web User Interface, Web Services for Products (WSD), WebDAV  NOTE: If Force Traffic over Secure Connection (HTTPS) is enabled, then all requests received for the Web Interface using HTTP/port 80 will be redirected over HTTPS/port 443, which is encrypted and secures communications.
68	UDP	DHC ACK Response to DHCP
88	UDP	Kerberos
110	TCP	POP3
139	TCP	NETBIOS
161	UDP	SNMP
137	UDP	NETBIOS (Name Service)
138	UDP	NETBIOS (Datagram Service)
161	UDP	SNMP
427	TCP/UDP	SLP
443	TCP	HTTPS – HTTP over TLS, IPPS
445	TCP	SMB
500 & 4500	TCP/UDP	IPsec
515	TCP	LPR
631	TCP	IPP
3702	TCP/UDP	WSD (Discovery)
4000	TCP	ThinPrint
5353	UDP	mDNS
5354	TCP	mDNS Responder IPC
9100	TCP	Raw IP or AppSocket
5909-5999	TCP	Remote Access to local display panel. Port is randomly selected, and communications encrypted with TLS 1.2 or 1.3
51333	TCP	File Sharing through Fleet Orchestrator
53202	TCP	WSD Transfer
53303	TCP	WSD Print
53404	TCP	WSD Scan

## Network Encryption

### IPSEC

Internet Protocol Security (IPsec) is a network security protocol capable of providing encryption and authentication at the packet level. AltaLink® products support IPsec for both IPv4 and IPv6 protocols.

NOTE: SHA1 is deprecated and considered insecure. Xerox recommends using SHA256 and above.

AltaLink® B8245/B8255/B8270 Multifunction Printer AltaLink® C8230/C8235/C8245/C8255/C8270 Color Multifunction Printer	
<b>IPsec</b>	
Supported IP Versions	IPv4, IPv6
Key exchange authentication method	Preshared Key & digital signature authentication (device authentication certificate, server validation certificate)
Transport Mode	Transport & Tunnel mode
Security Protocol	ESP & AH
ESP Encryption Method	AES, Null
ESP Authentication Methods	SHA1, SHA256, None

### WIRELESS 802.11 WI-FI PROTECTED ACCESS (WPA)

Products equipped with Wi-Fi support WPA3 Personal, WPA3 Personal Transitional, WPA3 Enterprise, WPA2 Personal, WPA2 Enterprise, and Mixed Mode. The wireless network adapters used in Xerox products are certified by the Wi-Fi Alliance.

AltaLink® B8245/B8255/B8270 Multifunction Printer AltaLink® C8230/C8235/C8245/C8255/C8270 Color Multifunction Printer	
<b>Wi-Fi (802.11)</b>	
No Encryption	Supported
WEP	RC4

WPA2 Personal (PSK)	CCMP (AES), TKIP, TKIP+CCMP (AES), PMF (Protected Management Frame) support optional Password-based authentication via Pre-Shared Key (PSK)
WPA2 Enterprise	CCMP (AES), TKIP, TKIP+CCMP (AES) PEAPv0 MS-CHAPv2 EAP-TLS EAP-TTLS/PAP EAP-TTLS/MS-CHAPv2 EAP-TTLS/EAP-TLS PMF (Protected management frame) support optional
WPA3 Personal (SAE)	CCMP (AES) PMF (Protected Management Frame) support required Password-based authentication via Simultaneous Authentication of Equals (SAE)
WPA3 Personal Transitional	WPA3 / WPA2 Personal CCMP (AES) PMF (Protected Management Frame) support optional Password-based authentication: WPA3-SAE/ WPA2- PSK
WPA3 Enterprise	CCMP (AES) PEAPv0 MS-CHAPv2 EAP-TLS EAP-TTLS/PAP EAP-TTLS/MS-CHAPv2 EAP-TTLS/EAP-TLS Server certificate validation required PMF (Protected Management Frame) support required
BSSID Roaming Restriction	Supported

### TLS

AltaLink® products support configurable TLS Versions and TLS Hash Algorithms for device features that use TLS.

NOTE: TLS 1.0 and 1.1 are deprecated and considered insecure. Xerox recommends using TLS 1.2 or higher.

NOTE: SHA1 is deprecated and considered insecure. Xerox recommends using SHA256 and above.

**AltaLink® B8245/B8255/B8270 Multifunction Printer**  
**AltaLink® C8230/C8235/C8245/C8255/C8270 Color Multifunction Printer**

<b>TLS</b>	
<p>TLS Versions</p>	<p>TLS 1.2 (recommended)            TLS 1.1 and TLS 1.2 (default), or TLS 1.0, TLS 1.1 and TLS 1.2            Note: In FIPS CCC mode TLS 1.0 or 1.1 are not supported.</p> <p>Include or not include TLS 1.3 checkbox</p>
<p>TLS Hash Algorithms</p>	<p>SHA-256 and above (recommended)            SHA-1, SHA-256 and above (default)            Note: The setting does not apply to Scan to Cloud and Print from Cloud features other than for authentication.</p>
<p>TLS Versions</p>	<p>TLS 1.2 (recommended)            TLS 1.1 and TLS 1.2 (default), or TLS 1.0, TLS 1.1 and TLS 1.2            Note: In FIPS CCC mode TLS 1.0 or 1.1 are not supported.</p> <p>Include or not include TLS 1.3 checkbox</p>
<p>TLS Hash Algorithms</p>	<p>SHA-256 and above (recommended)            SHA-1, SHA-256 and above (default)            Note: The setting does not apply to Scan to Cloud and Print from Cloud features other than for authentication.</p>

### SNMPV3

SNMPv3 is the current standard version of SNMP defined by the Internet Engineering Task Force (IETF). It provides three important security features:

Message integrity to ensure that a packet has not been tampered with in transit

Authentication to verify that the message is from a valid source Encryption of packets to prevent unauthorized access.

AltaLink® B8245/B8255/B8270 Multifunction Printer	
AltaLink® C8230/C8235/C8245/C8255/C8270 Color Multifunction Printer	
<b>SNMPv3</b>	
Digest	SHA1, MD5
Encryption	DES, AES128

## Public Key Infrastructure (PKI)

Digital certificates are a key component of public key infrastructure. A digital certificate contains information about the identity of an entity, the certificate authority that issued the certificate, and its associated public and private key pair. The certificate's private key is used to generate digital signatures, and the public key is used to validate those digital signatures. For entities to validate a digital signature, the certificate and its public key are shared freely. Trust is established by validating the certificate path, which contains the certificate authorities that issued the certificate.

### DEVICE CERTIFICATES

AltaLink® products support both CA signed and self-signed device certificates. The device certificates support a bit length of up to 4096 bits.

AltaLink® products require a device certificate. The MFP will use the device certificate as its identity. The MFP EWS certificate is an example of a device certificate. The device certificate must be issued by a certificate authority (CA) trusted by the device.

The Xerox device certificate, which is the default device certificate installed on the MFP, is issued by the Xerox Root CA embedded in the MFP firmware. The Xerox device certificate details are configurable and can be recreated as needed by the device administrator. The default expiry date is such that the expiry is at 397 days to meet current CA/browser standards, however the default can be overridden in configuration.

The MFP can be configured to use any installed CA signed certificate as its device certificate. To install a CA signed certificate, the device administrator can generate and download a Certificate Signing Request (CSR) from the MFP, have the CSR be signed by an Enterprise CA or 3rd Party CAs, and then import the CA signed certificate into the MFP. Alternatively, this process can be completed off-box and a CA signed certificate in PKCS #12 format can be imported into the MFP.

**AltaLink® B8245/B8255/B8270 Multifunction Printer  
AltaLink® C8230/C8235/C8245/C8255/C8270 Color  
Multifunction Printer**

<b>Device Certificates</b>	
Certificate Length	Up to 4096 (for RSA certificates)
Default Device Certificate	ECDSA P-384
Supported Hashes	SHA256
Product Web Server	Supported
IPPS Printing	Supported
802.1X Client	Supported
IPsec	Supported
SFTP	Supported

## TRUSTED CERTIFICATES

Public Root and Intermediate Root Certificate Authority (CA) certificates may be imported to the product's certificate store to establish trust with external products and services. The following categories are supported:

- A Root CA certificate is a certificate with authority to sign other certificates. These certificates usually are self-signed certificates that come from another product or service that you want to trust.
- An Intermediate CA certificate is a certificate that links a certificate to a Trusted Root CA Certificate in certain network environments.
- Peer Device certificates are installed on the printer for solution-specific uses.

NOTE: SHA1 is deprecated and considered insecure. Xerox recommends using SHA256 and above.

**AltaLink® B8245/B8255/B8270 Multifunction Printer  
AltaLink® C8230/C8235/C8245/C8255/C8270 Color  
Multifunction Printer**

<b>Trusted Certificates (CA &amp; Peer device)</b>	
Minimum RSA Key Length Restriction Options	None, 1024, 2048, 4096
Minimum ECDSA Key Length Restriction Options	256, 384
Maximum Length	4096
Supported Hashes	SHA1/224/256/384/512
IPsec	Supported
LDAP	Supported
Scanning (HTTPS/TLS)	Supported
Scanning (SFTP/SSH)	Used for audit log transfer
802.1X Client	Supported
Email Signing	Supported
Email Encryption	Supported
Email (STARTLS)	Supported
OCSP Validation	Supported

## MINIMUM KEY LENGTH

An administrator can independently specify the minimum encryption key length for RSA and ECDSA certificates used for encryption by the device. When a user imports a certificate to the device, that certificate's key length is validated against the minimum requirements. Certificates with key lengths that are less than the minimum key-length requirements are not installed, and a message alerts the user to the discrepancy. Additionally, a user is not able to change the device

minimum key-length setting, if doing so invalidates a certificate already installed on the device.

### ONLINE CERTIFICATE STATUS PROTOCOL (OCSP)

OCSP is supported to validate server certificates and related signing chains. OCSP validation is implemented for smart card authentication, and when the product is enabled for FIPS with CC Mode, for CC related features.

## Network Access Control

### 802.1x

In 802.1x authentication, when the product is connected to the LAN port of Authenticator such as the switch as shown below, the Authentication Server authenticates the product, and the Authenticator controls access of the LAN port according to the authentication result. The product starts authentication processing at startup when the startup settings for 802.1X authentication are enabled.

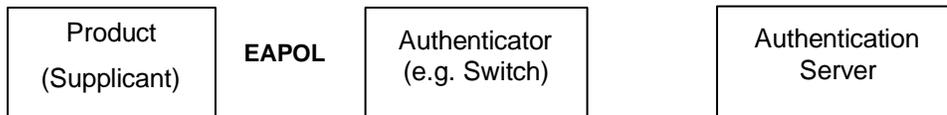

**AltaLink® B8245/B8255/B8270 Multifunction Printer**  
**AltaLink® C8230/C8235/C8245/C8255/C8270 Color Multifunction Printer**

Network Access Control	
802.1x	Supported
Authentication Methods	PEAPv0/EAP MSCHAPv2, EAP-MSCHAPv2, EAP-TLS

### CISCO IDENTITY SERVICES ENGINE (ISE)

Cisco ISE is an intelligent security policy enforcement platform that mitigates security risks by providing a complete view of which users and what products are being connected across the entire network infrastructure. It also provides control over what users can access your network and where they can go. Cisco's ISE includes over 200 Xerox product profiles that are ready for security policy enablement. This allows ISE to automatically detect Xerox products in your network. Xerox products are organized in Cisco ISE under product families, such as AltaLink® products, enabling Cisco ISE to automatically detect and profile new Xerox products from the day they are released. Customers who use Cisco ISE find that including Xerox products in their security policies is simpler and requires minimal effort.

Cisco ISE Profiling Services provides dynamic detection and classification of endpoints connected to the network. ISE collects various attributes for each network endpoint to build an endpoint database. The classification process matches the collected attributes to prebuilt or user-defined conditions, which are then correlated to an extensive library of product profiles. These profiles include a wide range of product types, including tablets, smartphones, cameras, desktop operating systems (for example, Windows®, Mac OS® X, Linux® and others), and workgroup systems such as

Xerox printers and MFPs.

Once classified, endpoints can be authorized to the network and granted access based on their profile signature. For example, guests to your network will have different levels of access to printers and other endpoints in your network. As an example, you and your employees can get full printer access when accessing the network from a corporate workstation but be granted limited printer access when accessing the network from your personal Apple® iPhone®.

Cisco ISE allows you to deploy the following controls and monitoring of Xerox products: Automatically provision and grant network access rights to printers and MFPs to prevent inappropriate access (including automatically tracking new printing products connecting to the network):

- Block non-printers from connecting on ports assigned to printers
- Prevent impersonation (aka spoofing) of a printer/MFP
- Automatically prevent connection of non-approved print products
- Smart rules-based policies to govern user interaction with network printing products

Provide simplified implementation of security policies for printers and MFPs by:

- Providing real-time policy violation alerts and logging
- Enforcing network segmentation policy
- Isolating the printing products to prevent general access to printers and MFPs in restricted areas

Automated access to policy enforcement:

- Provide extensive reporting of printing product network activity

**AltaLink® B8245/B8255/B8270 Multifunction Printer**  
**AltaLink® C8230/C8235/C8245/C8255/C8270 Color Multifunction Printer**

<b>Network Access Control</b>	
Cisco ISE	Supported

### CONTEXTUAL ENDPOINT CONNECTION MANAGEMENT

Traditionally network connection management has been limited to managing endpoints by IP address and use of VLANs and firewalls. This is effective, but highly complex to manage for every endpoint on a network. Managing, maintaining, and reviewing the ACLs (and the necessary change management and audit processes to support them) quickly become prohibitively expensive. It also lacks the ability to manage endpoints contextually.

Connectivity of AltaLink® devices can be fully managed contextually by Cisco TrustSec®. TrustSec uses Security Group Tags (SGT) that are associated with an endpoint's user, device, and location attributes. SG-ACLs can also block unwanted traffic so that malicious reconnaissance activities and even remote exploitation from malware can be effectively prevented.

### FIPS140-3 COMPLIANCE VALIDATION

When enabled for FIPS 140-3, cryptographic functions are FIPS 140-3 compliant. When also enabled with Common Criteria compliance, some cryptographic functions are further restricted to

the requirements of Common Criteria.

## Additional Network Security Controls

### **IP FILTERING**

The devices contain a static host-based firewall that provides the ability to prevent unauthorized network access based on IP address and/or port number. Filtering rules can be set by the SA using the Embedded Web Server. An authorized SA can create rules to (Accept/Reject/Drop) for ALL or a range of IP addresses. In addition to specifying IP addresses to filter, an authorized SA can enable/disable all traffic over a specified transport layer port.

### **PERSONAL IDENTIFIABLE INFORMATION (PII)**

Personal Identifiable Information (PII) can be entered or stored into the device through several means: address book, scan templates, device description, display device information, audit logs, and engineering logs. The PII is encrypted on the device, and it is not readable outside of the operation of the device. The admin controls users' ability to enter data and the accessibility of logs, or they may be resident.

## 5. Device Security: UEFI, Firmware, OS, Runtime, and Operational Security Controls

AltaLink® products have robust security features that are designed to protect the system from a wide range of threats. Below is a summary of some of the key security controls.

### Pre-Boot Security

#### BIOS

The embedded Unified Extensible Firmware Interface (UEFI) used in AltaLink® products cannot be accessed by users. Unlike devices such as desktop and laptop computers that have a UEFI that can be accessed via a keystroke on startup, the UEFI of AltaLink® products is not accessible.

UEFI updates can be securely applied by device firmware updates. Firmware is protected from tampering by use of digital signatures (discussed later in this section).

The UEFI is designed to fail secure. An integrity check is performed immediately when power is applied. If verification is successful, the system proceeds with OS kernel boot. If the integrity check fails, the system will fail secure.

#### EMBEDDED ENCRYPTION

AES encryption is used to protect the system, user data, and configuration (including security settings) from being retrieved or modified. Each device uses its own unique key that is securely generated. Encryption is always enabled by default. Media encryption and sanitization are discussed in Section 3 User Data Protection.

### Boot Process Security

#### TRUSTED BOOT

Xerox® AltaLink® MFPs utilize a Trusted Boot process to enable a secure boot utilizing Intel® Boot Guard and the Unified EFI Forum/Microsoft specified (UEFI) approach to ensure a verified Chain of Trust is utilized to perform the MFP boot process. This process establishes a root of trust extending from the Intel processor to the UEFI and continuing to the Boot Manager and the Xerox Firmware. The startup process verifies that the installation software/firmware has not been altered, giving the customer assurance that the code has not been altered or replaced.

## FIRMWARE INTEGRITY

Unlike open operating systems such as servers and user workstations in which software may be installed by users, Xerox products are based on embedded systems and the contents are managed by Xerox. The only means of modifying the contents of a device is by applying a firmware update package.

Firmware updates use a special format, and each firmware update is encrypted and digitally signed to protect the integrity of the contents. Firmware that is corrupt or has been illicitly modified will be rejected. This security control cannot be disabled. AltaLink® products include a built-in firmware software validation. This is a file integrity monitor that compares the security hashes of currently installed firmware to a secured whitelist that was installed when the signed firmware was installed.

Although there is ongoing firmware verification with the Trellix™ Embedded Control (formerly known as McAfee Embedded Control), an administrator can at any time invoke a check on the current executable software on the machine to verify it has not been altered or replaced. This complies with Common Criteria Certification requirements. This Software Verification Test can be invoked at the WebUI at any time. This feature utilizes FIPS 1403 and CCC approved SHA256 digests of the software to validate its integrity.

## FIRMWARE RESTRICTIONS

The list below describes the most used supported firmware delivery methods and applicable access controls.

Local Firmware Upgrade via USB port:

Xerox service technicians typically update product firmware using a USB port and a specially configured USB thumb drive for recovering non-functional machines or use a laptop with special serial cables and a network cable for recovering non-functional machines.

Network Firmware Update:

Product system administrators can update product firmware using the Embedded Web Server. The ability to apply a firmware update is restricted to roles with system administrator or Xerox service permissions. Firmware updates can be disabled by a system administrator.

Xerox Remote Services Firmware Update:

Xerox Remote Services can update product firmware securely over the internet using HTTPS. This feature can be disabled, scheduled, and includes optional email alerts for system administrators.

The programs stored in the Flash ROM listed below are downloadable from external sources:

- Controller
- Marking
  - Engine
  - Scanner
  - Document
  - Feeder
- Finisher (Option for processing printed paper. No description on Finisher is provided in this document because user's image data will not be stored in it.)
- High Capacity Feeder (No description on high capacity feeder is provided in this document because user's image data will not be stored in it.)

- High Capacity Stacker (No description on high capacity stacker is provided in this document because user's image data will not be stored in it.)
- Interface Module (No description on interface module is provided in this document because user's image data will not be stored in it.)

The downloading function can be disabled by a system administrator from the Local UI or the Embedded Web Server.

For additional information on Firmware update methods such as lpr, raw tcp/ip printing, Fleet Orchestrator, and various upgrade methods supported, please see the System Administrator Guide.

## Runtime Security

Each AltaLink® device comes with Trellix Embedded Control built in and enabled by default and cannot be disabled. Trellix Embedded Control is used to protect a variety of endpoints that range from wearable devices to critical systems controlling electrical generation.

Executable control prevents unauthorized code from executing. Xerox has defined a whitelist of executable programs; software that is not on the secure whitelist is not allowed to execute. Trellix cannot be disabled on AltaLink® products; it is always enabled.

When an anomaly is detected, it is logged to the device audit log and optional alerts are immediately sent via email. Events are also reportable through CentreWare® Web or Xerox Device Manager, and Trellix ePolicy Orchestrator (Trellix ePO).

## Event Monitoring and Logging

### CONFIGURATION WATCHDOG

The AltaLink® Configuration Watchdog feature allows Administrators to configure the periodic monitoring of multiple security related areas, each with one or more settings, totaling over 75 individual settings. If, during a check, a monitored security setting is discovered to have been changed, the system will automatically remediate it. In the case that remediation is unsuccessful, an email alert is generated, and the event is captured in the Audit Log (see below for information on the Audit Log). For a list of the security settings covered, please see the System Administrator Guide.

### AUDIT LOG

The Audit Log feature records security-related events. The Audit Log contains the following information:

Field	Description
<b>Index</b>	A unique value that identifies the event
<b>Date</b>	The date that the event happened in mm/dd/yy format
<b>Time</b>	The time that the event happened in hh:mm:ss format
<b>ID</b>	The type of event. The number corresponds to a unique description
<b>Description</b>	An abbreviated description of the type of event

<b>Additional Details</b>	<p>Columns 6–10 list other information about the event, such as:</p> <p>Identity: User Name, Job Name, Computer Name, Printer Name, Folder Name, or Accounting Account ID display when Network Accounting is enabled.</p> <p>Completion Status</p> <p>Image Overwrite Status: The status of overwrites completed on each job. Immediate Image must be enabled.</p>
---------------------------	--

AltaLink® products currently support over two hundred unique events. A maximum of 15,000 events can be stored on the device. When the Audit Log reaches 13,500 entries (90% “full”), an email alert will be sent. When it reaches 28,500 events, the device will send another message stating there have been 15,000 events since the last alert. The device will keep alerting at 15,000 event intervals. When the number of events exceeds 15,000, audit log events will be deleted in timestamp order, and then new events will be recorded. The audit log can be exported at any time by a user with administrative privileges. Note that as a security precaution, audit log settings and data can only be accessed via HTTPS and Audit Log can’t be disabled on this version of AltaLink® products.

#### SECURITY INFORMATION EVENT MANAGEMENT (SIEM) SUPPORT

Xerox® AltaLink® supports the ability to directly connect to industry leading security and event management (SIEM) systems. Once configured, Xerox® AltaLink® B8245/B8255/B8270 Multifunction Printer C8230/C8235/C8245/C8255/C8270 Color Multifunction Printer sends security information, along with the event severity, to the SIEM system for processing and reporting. Events are generated as they occur and are transmitted in Common Event Format (CEF), which a SIEM system can interpret. The firmware supports connection to any event ingestion system that uses syslog (UDP, TCP, and TLS) such as Trellix Enterprise Security Manager, LogRhythm, and Splunk Enterprise Security.

## Operational Security

#### SERVICE TECHNICIAN (CSE) ACCESS RESTRICTION

The CSE (Customer Service Engineer) account allows a Xerox Technician to access the MFP’s diagnostics and maintenance routines. The CSE role has only ‘guest privileges’ to the other user interfaces including the Local and Embedded Web Server. However, CSE access to these other interfaces can be restricted if needed.

If users require additional restrictions on the Customer Service Engineer Account, a setting is available within the Embedded Web Server to lock these services accounts. A qualified Xerox Service technician will need the machine administrator to grant access to the machine.

#### ADDITIONAL SERVICE DETAILS

Xerox products are serviced by a tool referred to as the Portable Service Workstation (PWS). Only Xerox-authorized service technicians are granted access to the PWS. Customer documents or files cannot be accessed during a diagnostic session, nor are network servers accessible through this port. If a network connection is required while servicing a Xerox device, service technicians will remove the device from any connected networks. The technician will then connect directly to the device using an Ethernet cable, creating a physically secure and isolated network during service operations.

## CLONING

Certain system settings can be captured (copied) in a clone file that may be installed on other AltaLink® systems. Clone files are encrypted and digitally signed. AltaLink® MFP does support installing newer clone files created on other AltaLink® devices. Access to both creating and installing a clone file can be restricted using role-based access controls. Clone files can only be created through the Embedded Web Server or via USB at the Local UI. Clone files can be installed through the following methods: Embedded Web Server, USB at the Local UI, Web service, submission as a print job, or file distribution. Submitting a clone file as a print job may be disabled, temporarily or permanently.

## BACKUP AND RESTORE

Like cloning, backup and restore, can capture (copy) certain system and device-specific settings in a backup file. Backup files are like clone files as they are encrypted and digitally signed. This file may be reapplied to the same device at any time. Access to both create and restore a backup file can be restricted using role-based access controls. Backup files can only be created and applied through the Embedded Web Server. This backup can be stored at the device or exported, and the exported file is encrypted and signed.

## EIP APPLICATIONS

Xerox products can offer additional functionality through the Xerox Extensible Interface Platform® (EIP). Third party vendors can create Apps that extend the functionality of a product. Xerox signs EIP applications that are developed by Xerox or Xerox partners. Products can be configured to prevent installation of unauthorized EIP applications. Discussion of individual EIP application security is beyond the scope of this document. EIP applications utilize the security framework provided by the Third-party vendor and the EIP configuration of the product. Please consult documentation for individual EIP application as provided by the Third-party vendor for security details.

## 6. Configuration and Security Policy Management Solutions

This section describes various functionalities available in the Xerox® AltaLink® products that help create and document operational workflows for network security management and orchestration.

### SECURITY DASHBOARD

Using a structured approach based on NIST recommended grouping of security features (Authentication, Confidentiality, Integrity, and Availability), the Security Dashboard has been created to assist System Administrators, and to provide a quick overview of this AltaLink® MFP's security settings. All security settings are displayed on a single Embedded Web Server page, with links to the appropriate web pages for easy access and easy configuration.

### XEROX DEVICE MANAGER AND XEROX® CENTREWARE® WEB

Xerox Device Manager and Xerox® CentreWare® Web (available as a free download) centrally manage Xerox Devices. Additionally, AltaLink® products come with Trellix built in and can be managed with Trellix ePO™ providing an enhanced security posture supporting proactive monitoring, threat detection, and remediation capabilities. For details, please visit Xerox.com or speak with a Xerox representative.

### FLEET ORCHESTRATOR

Fleet Orchestrator allows the System Administrator to configure many devices in similar ways, automatically. After a device is configured, the System Administrator can distribute clone files with configuration settings to other devices in its Trust Community. The System Administrator sets up schedules to share configuration settings and files regularly and automatically. Additionally, the System Administrator can configure Fleet Orchestrator to reapply files on a given schedule to keep the configuration of the devices consistent. Auto-Assembly builds on Fleet Orchestrator by enabling devices to find and join a Trust Community in their network. This automates the addition of devices to the Trust Community for the System Administrator.

### UNIVERSAL PRINT

This option enables Microsoft Universal Print which leverages Microsoft Azure AD security mechanisms. The MFP uses public/private key exchange to request an OAUTH2 access token issued by Azure. The MFP generates a JSON Web Token and signs it with its certificate private key. The Azure-generated access token provides MFP access to the Azure cloud. Individual Universal Print users are provided authorization to the MFP by the Azure Administrator. All the data in transit is encrypted using HTTPS with TLS 1.2.

### IMAGING SECURITY

Xerox® AltaLink® 8200 Series offers an innovative feature called Imaging Security. This feature

helps customers protect sensitive information from intentional or unintentional disclosure by utilizing a proprietary Infra-red printing technology to mark documents (AltaLink® C8200 series only) and take action based on the presence of an IR mark (both AltaLink® B8200 and C8200 Series). Customers may choose to mark all Copy jobs and/or all Print or Secure Print jobs. This method of marking can prevent the accidental disclosure of sensitive documents and ease our customers' concerns around sensitive document management. For additional information on how to use this feature, please see the System Administrator Guide.

#### **PRE-DEFINED SECURITY TEMPLATE WIZARD**

Xerox® AltaLink® 8200 Series offers an innovative feature called The Security Template Wizard which creates an easy-to-follow quick setup for security configuration and can be run at the install wizard or can be initiated from the walkup user interface.

#### **REGISTER CARDS WITH AUTHENTICATION METHODS**

Customers now can utilize cards and card readers without the need for an authentication software solution. When enabled, users walk up to the printer and swipe their card to login. If the card is not registered with the printer, the user is prompted to login. Upon successfully entering their credentials, the same card can be used to login or logout of the printer. This capability is supported with local login, network login, and cloud IdP login.

Note: Card information is stored locally in the MFD's encrypted NVMe SSD, and require registration on each individual MFD

#### **SECURE RELEASE FOR MICROSOFT® UNIVERSAL PRINT**

Microsoft® Universal Print now leads the industry with the Secure Release capability. Customers are no longer required to install additional software on clients, nor do users need to explicitly enter PINs to release their secure print jobs. Additionally, secure print jobs are not transmitted to the printer until the owner logs into the device, thus saving network bandwidth and cost. Once the walk-up user authenticates the device, their secure print jobs are available to print, if they desire.

#### **SECURE PRINT FOR MICROSOFT® UNIVERSAL PRINT**

The capabilities of Microsoft® Universal Print continue to be enhanced. Universal Print now supports the option to send jobs with a Secure Print PIN that is encrypted with the job. These jobs align with the Device Policies and Defaults settings that the device administrator can set in the "Secure Print" section of the Embedded Web Server (EWS).

## 7. Identification, Authentication, and Authorization

AltaLink® products offer a range of authentication and authorization options to support various environments.

Single Factor authentication is supported locally on the product or via external network authentication servers (e.g., LDAP, Kerberos, ADS). Multi Factor authentication is supported by the addition of card reader hardware. (Where ease of access is desired, open access and simple user identification modes also exist, however, these are not recommended for secure environments.)

In all modes, product administrator accounts always require authentication. This cannot be disabled.

A flexible RBAC (Role-Based Access Control) security model enables granular control to assign user permissions. Once a user has been authenticated, the product grants (or denies) user permissions based upon the role(s) they have been assigned to. Pre-defined roles that may be used or custom roles may be created as desired.

### Authentication

Xerox® AltaLink® devices support the following authentication mode:

- Local  
Authentication  
Network  
Authentication
- Smart Card Authentication (CAC, PIV, SIPR, etc.)  
Convenience Authentication
- Xerox Workplace Cloud
- Identity Provider (IdP) – Validate on Cloud

#### LOCAL AUTHENTICATION AND AUTHORIZATION

The local user database stores user credential information on the MFD's encrypted NVMe SSD. The printer uses this information for local authentication and authorization, and for Xerox Standard Accounting. When you configure local authentication, the printer checks the credentials that a user provides against the information in the user database. When you configure local authorization, the printer checks the user database to determine which features the user is allowed access. Each device has a unique default administrator password which should be changed as soon as possible, along with enabling recommended security features to secure the system.

**Note:** Usernames and passwords stored in the user database are not transmitted over the network and passwords are encrypted.

## PASSWORD POLICY

The following password attributes can be configured:

Password Policy	
Minimum Length	1
Maximum Length	63
Default Minimum	4
Password cannot contain Username	Supported
Password complexity options (in addition to alphabetic characters)	Can be set to require a number, an upper-case character, lower case character and a special character

Admin password can be set using any character within the printable Unicode and the AltaLink® default administrator password meets the 2020 California Password Law (SB-327). This law states that each 'internet-connectable' device must have a unique password by default. These devices also meet the UK PSTI.

Statement of Compliance:

It is the opinion of Xerox Corporation that the Xerox® AltaLink B82xx and C82xx Series are in conformance with the applicable security requirements in Schedule 1 of "The Product Security and Telecommunications Infrastructure (PSTI) Act of 2023".

All newly sold Xerox devices are delivered with a unique generated default administrator password. It is recommended the customer change this new default administrator password, as soon as possible, to a strong password that the customer can use and recall.

## NETWORK AUTHENTICATION

When configured for network authentication, user credentials are validated by a remote authentication server.

Network Authentication Providers	
Kerberos (Microsoft Active Directory)	Supported
Kerberos (MIT)	Supported
SMB NTLM Versions Supported	NTLMv2
LDAP Versions Supported	Version 3

## SMART CARD AUTHENTICATION

Smart Card authentication is considered very secure due to the nature of the Smart Card architecture and potential levels of encryption of data on the card itself. It provides two-factor security: 1) a PIN is required to unlock the smart card and 2) the user's smart card credential is authenticated over the network using Kerberos PKINIT authentication.

Smart Card Authentication requires card reader hardware. Please contact Xerox Support for a list

of supported cards and card readers.

Smart Cards	
Common Access Card (CAC)	Supported
PIV/ PIV II	Supported
Gemalto MD	Supported
SIPR	Supported

Support for the SIPR network is provided using a Smart Card authentication solution created by 90meter under contract for Xerox. Details regarding 90meter can be found online here: <https://www.90meter.com/>

#### CONVENIENCE AUTHENTICATION

Convenience authentication offloads authentication to a third-party solution which may offer more or less security than native security implementations. Users swipe a pre-programmed identification card or key fob to access the device.

For example, employees may be issued key fobs for access to facilities. Convenience mode may be configured to allow an employee to authenticate using their fob or require the fob in a multi-factor manner. The level of security provided is dependent upon the chosen implementation.

Some examples of third-party convenience authentication providers include:

- Xerox Workplace Cloud <https://www.xerox.com/>
- Pharos Print Management Solutions <https://pharos.com>
- YSoft SafeQ <https://www.ysoft.com/en>

Contact your Xerox sales representative for details and other options.

#### XEROX WORKPLACE CLOUD

This option enables cloud-based authentication. The printer connects directly to the Xerox® Workplace Cloud solution. This method provides multiple options for authentication. For additional information on how to use this feature, please see the System Administrator Guide.

#### IDENTITY PROVIDER (IDP) – VALIDATEON CLOUD

This option enables cloud-based authentication through an identity provider (IdP). The device establishes a secure connection with the IdP, then passes the user credentials to the IdP for authentication.

The IdP service's certificate authority (CA) chain of trust certificate(s) is used by the MFP to validate the IdP service's server authentication certificate. The IdP issues a SAML token on a per session basis for the user to access their authorized services. This token is destroyed after each session.

Examples of supported IdPs are Ping Identity, Microsoft Azure, and Okta.

## Authorization (Role-Based Access Controls)

AltaLink® products offer granular control of user permissions. Users can be assigned to pre-defined roles or customers may design highly flexible custom permissions. A user must be authenticated before being authorized to use the services of the product. Authorization ACLs (Access Control Lists) are stored in the local user database. Authorization privileges (referred to as permissions) can be assigned per user or group.

Please note that Xerox products are designed to be customizable and support various workflows as well as security needs. User permissions include security-related permissions and non-security related workflow permissions (e.g., walkup user options, copy, scan, plex, etc.). Only security-related permissions are discussed here.

## REMOTE ACCESS

Without RBAC permissions defined, basic information such as model, serial number, and software version can be viewed by unauthenticated users. This can be disabled by restricting access to the device website pages for non-logged-in users.

By default, users can view basic status and support related information, but they are restricted from accessing device configuration settings. Permission to view this information can be disallowed.

## LOCAL ACCESS

Without RBAC permissions defined, basic information such as model, serial number, software version, IP address, and host name can be viewed without authentication. This can be disabled by disallowing access to device settings for unauthenticated users.

By default, users can access the local interface, but they are restricted from accessing device configuration settings. Roles can be configured to allow granular access to applications, services, and tools. Users can be also restricted from accessing the local interface completely.

## 8. Additional Information and Resources

### Security @ Xerox®

Xerox maintains an evergreen public web page that contains the latest security information pertaining to its products. Please see <https://www.xerox.com/security>

### Responses to Known Vulnerabilities

Xerox has created a document which details the Xerox Vulnerability Management and Disclosure Policy used in discovery and remediation of vulnerabilities in Xerox software and hardware. It can be downloaded from this page: <https://www.xerox.com/information-security/information-security-articles-whitepapers/enus.html>

### Additional Resources

Below are additional resources.

Security Resource	URL
Frequently Asked Security Questions	<a href="https://www.xerox.com/en-us/information-security/frequently-asked-questions">https://www.xerox.com/en-us/information-security/frequently-asked-questions</a>
Common Criteria Certified Products	<a href="https://security.business.xerox.com/en-us/documents/common-criteria/">https://security.business.xerox.com/en-us/documents/common-criteria/</a>
Current Software Release Quick Lookup Table	<a href="https://www.xerox.com/security">https://www.xerox.com/security</a>
Bulletins, Advisories, and Security Updates	<a href="https://www.xerox.com/security">https://www.xerox.com/security</a>
Security News Archive	<a href="https://security.business.xerox.com/en-us/news/">https://security.business.xerox.com/en-us/news/</a>

## 9. Appendix A: Product Security Profiles

This appendix describes specific details of each AltaLink® product.

AltaLink® B8145/B8155/B8170/B8200 & C8130/C8135/C8145/C8155/C8170/C8200

### PHYSICAL OVERVIEW

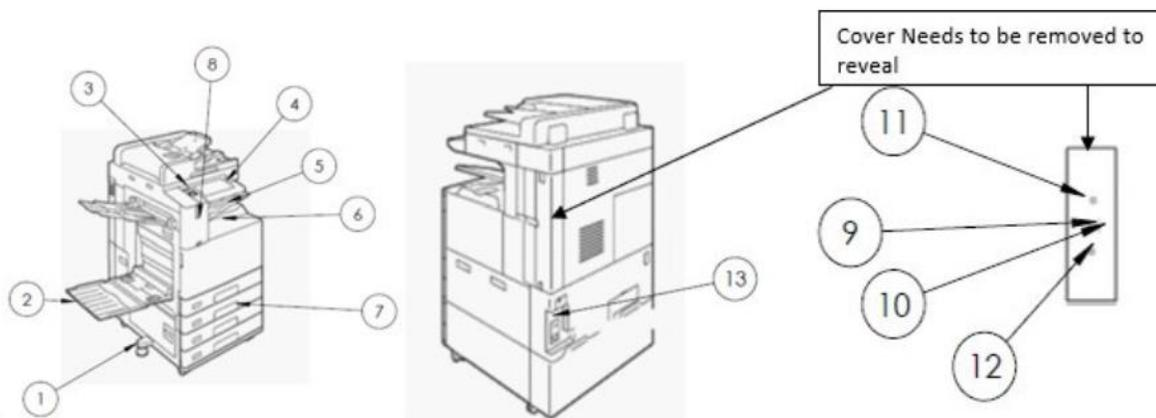

- |                                  |  |
|----------------------------------|--|
| 15. Stabilizer                   | 22. Smart Proximity Sensor.                              |
| 16. Bypass paper feed tray.      | 23. Rear USB Port(s)*                                    |
| 17. Front USB Port(s)*           | 24. Wireless Network Adapter with Bluetooth*             |
| 18. Touch screen user interface. | 25. RJ45 Ethernet connection*                            |
| 19. Upper paper tray.            | 26. Service port<br>(May require disassembly to access). |
| 20. Lower paper tray.            | 27. AC Power   |
| 21. Paper feed trays.            | 28. *Denotes a security related component                |

## SECURITY RELATED INTERFACES

Security Related Interfaces	
<b>Ethernet</b>	10/100/1000 MB Ethernet interface.
<b>Optional Dual Band</b>	Supports optional 802.11 Dongle.
<b>Optional Wireless Network Adapter with Bluetooth</b>	Supports dual band Wi-Fi, Wi-Fi Direct, and iBeacon for AirPrint Discovery through Bluetooth Low Energy Beacons.
<b>Rear USB 3.0 (Type B)</b>	USB target connector used for printing. Note: This port can be disabled completely by a system administrator.
<b>Front &amp; Rear USB2.0 (Type A) port(s)</b>	Users may insert a USB thumb drive to print from or store scanned files to. (Physical security of this information is the responsibility of the user or operator.) Note that features that leverage USB ports (such as Scan To USB) can be disabled independently based on services. Firmware upgrades may be applied using this port. Connection of optional equipment such as NFC or CAC readers. Note: This port can be disabled completely by a system administrator.

## CONTROLLER NON-VOLATILE STORAGE

Model	Size	Type	Use	User Data	How to Clear
<b>B8270, B8255, B8245, C8230, C8235, C8245, C8255, C8270</b>	256 GB	NVMe SSD*	Contains User Data (e.g., Print, Scan, Fax) and Configuration Settings. This data is encrypted, and Encryption is always on	Yes	Factory Reset
<b>B8270, B8255, B8245, C8230, C8235, C8245, C8255, C8270</b>	1 TB	NVMe SSD**	Contains User Data (e.g., Print, Scan, Fax) and Configuration Settings. This data is encrypted, and Encryption is always on	Yes	Factory Reset

\*SSD: Solid State Drive, is a Standard Configuration

\*\*SSD: Solid State Drive, is an Optional Configuration

#### CONTROLLER VOLATILE MEMORY

Model	Size	Type	Use	User Data	How to Clear
<b>B8270, B8255, B8245, C8230, C8235, C8245, C8255, C8270</b>	4 GB	DDR3 DRAM	Executable code, Printer control data, temporary storage of job data	Yes	Power off system
<b>C8270</b>	8 GB	DDR3 DRAM	Executable code, Printer control data, temporary storage of job data	Yes	Power off system

**Additional Information:** The controller operating system memory manager allocates memory dynamically between OS, running processes, and temporary data which includes jobs in process. When a job is complete, the memory pages in use are freed and reallocated as required by the OS.

#### MARKING ENGINE NON-VOLATILE STORAGE

The marking engine does not contain any non-volatile storage.

#### MARKING ENGINE VOLATILE MEMORY

The marking engine volatile memory does not store or process user data.

## 10. Appendix B: Security Events

### AltaLink® Security Events

ID	Event	Description
1	System Startup	Device Name Device Serial Number
2	System Shutdown	Device Name Device Serial Number
5	Print Job	Job Name User Name Source Service Name Completion Status IIO Status Accounting User ID Accounting Account ID
6	Network Scan Job	Job Name User Name Completion Status IIO status Accounting User ID Accounting Account ID Total Number Net Destination Net Destination
7	Server Fax Job	Job Name User Name Completion Status IIO Status Accounting User ID Accounting Account ID Total Fax Recipient Phone Numbers Fax Recipient Phone Numbers Net Destination
9	Email Job	Job Name User Name Completion Status IIO Status Accounting User ID Accounting Account ID Encryption On or Off Total Number of SMTP Recipients
		SMTP Recipients

12	Copy Job	Job Name User Name Completion Status IIO Status Accounting User ID Accounting Account ID
13	Embedded Fax Job	Job Name User Name Completion Status IIO Status Accounting User ID Accounting Account ID Total Fax Recipient Phone Numbers Fax Recipient Phone Numbers
14	LAN Fax Job	Job Name User Name Completion Status IIO Status Accounting User ID Accounting Account ID Total Fax Recipient Phone Numbers Fax Recipient Phone Numbers
20	Scan to Mailbox Job	Job Name or Directory Name User Name Completion Status IIO Status Accounting User ID Accounting Account ID
21	Delete File/Dir	Service (Print/Scan To Mailbox) Job Name or Directory Name User Name Completion Status IIO Status
23	Scan to Home	User Name Device Name Device Serial Number Completion Status (Enabled/Disabled)
24	Scan to Home Job	Job Name or Directory Name User Name Completion Status (Normal/Error) IIO Status
		Accounting User ID Name Accounting Account ID Name Total Number Net Destination Net Destination

26	Supplies Plan Activation and Plan Conversion	Device Name Device Serial Number Completion Status: Success (if Passcode is okay) Failed (if Passcode is not okay) Locked Out (if max attempts exceed 5)
27	Postscript Passwords	Device Name Device Serial Number Startup Mode or System Params Password or Start Job Password Completion Status
29	Network User Login	User Name Device Name Device Serial Number Completion Status (Success/Failed)
30	SA Login	User Name Device Name Device Serial Number Completion Status (Success/Failed)
31	User Login	User Name Device Name Device Serial Number Completion Status (Success/Failed)
32	Service Login Diagnostics	Service Name Device Name Device Serial Number Completion Status (Success/Failed)
33	Audit Log Download	User Name Device Name Device Serial Number Destination (WebUI, USB drive) Completion Status (Success/Failed)
35	SA Pin Changed	User Name Device Name Device Serial Number Completion Status Interface (Web   Local   SNMP   Web Service) Session IP Address ( If Available)
36	Audit Log File Saved	User Name Device Name Device Serial Number Completion Status

37	Force Traffic over Secure Connection (HTTPS)	User Name Device Name Device Serial Number Completion Status (Enabled/Disabled/Terminated)
38	Security Certificate	User Name Device Name Device Serial Number Completion Status (Created/Uploaded/Downloaded/Deleted)
39	IPsec	User Name Device Name Device Serial Number Completion Status (Configured/Enabled/Disabled/Terminated)
40	SNMPv3	User Name Device Name Device Serial Number Completion Status (Configured/Enabled/Disabled/Terminated)
41	IP Filtering Rules	User Name Device Name Device Serial Number Completion Status (Rule Added/Rule Edited/Rule Deleted)
42	Network Authentication Configuration	User Name Device Name Device Serial Number Completion Status (Configured/Enabled/Disabled)
43	Device Clock	User Name Device Name Device Serial Number Completion Status (Time Zone Changed/Date/Time Changed/Time Format Changed/Date Format Changed)
44	Software Upgrade	User Name Device Name Device Serial Number Completion Status (Success/Failed)
45	Clone File Operations	User Name Device Name Device Serial Number Completion Status
46	Scan Metadata Validation	Device Name Device Serial Number Completion Status (Success/Failed)
47	Xerox Secure Access Configuration	User Name Device Name Device Serial Number Completion status (Configured/Enabled/Disabled)

48	Service Login Copy Mode	Service Name Device Name Device Serial Number Completion Status (Success/Failed)
49	Smartcard Login	User Name (if valid Card and Password are entered)
		Device Name Device Serial Number Completion Status (Success/Failed)
50	Process Terminated	Device Name Device Serial Number Process Name Termination Reason
53	Saved Job Backup	File Name User Name Completion Status (Normal/Error) IIO Status
54	Saved Job Restore	File Name User Name Completion Status (Normal/Error) IIO Status
57	Session Timer Logout	Device Name Device Serial Number Interface (WebUI, LUI, CAC) User Name (who was logged out) Session IP (if available)
58	Session Timer Interval Change	Device Name Device Serial Number Interface (WebUI, LUI, CAC) (Timer affected by change) User Name (who made this change) Session IP (if available) Completion Status (Success/Failed)
59	User Permissions	User Name Device Name Device Serial Number Completion Status (Enabled/Disabled/Configured) Interface (WebUI, LUI, CAC, SNMP) Session IP Address (if available)
60	Device Clock NTP Configuration	Device Name Device Serial Number Enable/Disable/Config NTP NTP Server (IP Address/Hostname and Server Port) Completion Status (Success/Failed)

61	Device Administrator Role Permission	User Name (of user making the change) Device Name Device Serial Number User Name (of target user) Grant or Revoke (the admin right) Completion Status (Success/Failed)
62	Smartcard Configuration	User Name Device Name Device Serial Number Card Type (SIPR Token, CAC/PIV) Completion Status (Success/Failed)
63	IPv6 Configuration	User Name Device Name Device Serial Number Completion Status (Success/Failed)
64	802.1x Configuration	User Name Device Name Device Serial Number Completion Status (Enabled/Configured Wired/Disabled)
65	Abnormal System Termination	Device Name Device Serial Number
66	Local Authentication Enablement	User Name Device Name Device Serial Number Completion Status (Enabled/Disabled)
67	Web User Interface Login Method	User Name Device Name Device Serial Number Authentication Method Enabled (Network/Local)
68	FIPS Mode Configuration	User Name Device Name Device Serial Number Completion Status (Enable/Disable/Configure)
69	Xerox Secure Access Login	User Name Device Name Device Serial Number Completion Status (Success/Failed)
70	Print from USB Enablement	User Name Device Name Device Serial Number Completion Status (Enabled/Disabled)
71	USB Port Enablement	User Name Device Name Device Serial Number USB Port ID Completion Status (Enabled/Disabled)

72	Scan to USB Enablement	User Name Device Name Device Serial Number
		Completion Status (Enabled/Disabled)
73	System Log Download	Username Device Name File Names Downloaded Destination (IP address or USB device) Completion Status (Success/Failed)
74	Scan to USB Job	Job Name User Name Completion Status IIO Status Accounting User ID Name Accounting Account ID Name
75	Remote Control Panel Configuration	User Name Device Name Device Serial Number Completion Status (Enabled/Disabled/Configured)
76	Remote Control Panel Session	User Name Device Name Device Serial Number Completion Status (Initiated/Terminated) Remote Client IP Address
77	Remote Scan Feature Enablement	User Name Device Name Device Serial Number Completion Status (Enable/Disable)
78	Remote Scan Job Submitted	User Name (at client if available) IP Address of Submitting Client Device Name Device Serial Number Job Name (if accepted) Completion Status (Accept/Reject/Request)
79	Remote Scan Job Completed	Job Name User Name Accounting User ID Name Accounting Account ID Name Completion Status (Destination)
80	SMTP Connection Encryption	User Name Device Name Device Serial Number Completion Status (Enabled for STARTLS/ Enabled for STARTLS if available/ Enabled for TLS/Disabled/Configured)

81	Email Domain Filtering Rule	User Name Device Name Device Serial Number Completion Status (Feature Enabled/Feature Disabled/Rule Added/Rule Deleted)
82	Software Verification Test Started	Device Name Device Serial Number
83	Software Verification Test Complete	Device Name Device Serial Number Completion Status (Success/Failed/Cancelled)
84	Trellix Embedded Security State	User Name Device Name Device Serial Number Security Mode (Enhanced Security/Integrity Control) Completion Status (Enabled/Disabled/Pending)
85	Trellix Embedded Security Event	Device Name Device Serial Number Type (Read/Modify/Execute/Deluge) Trellix Message Text
87	Trellix Embedded Security Agent	User Name Device Name Device Serial Number Completion Status (Enabled/Disabled)
88	Digital Certificate Import Failure	Device Name Device Serial Number Email Address of Requestor (if available) Failure Reason (Invalid Address/Invalid Certificate/Invalid Signature)
89	Device User Account Management	User Name (Managing User Names) Device Name Device Serial Number User Name Added or Deleted Completion Status (Created/Deleted)
90	Device User Account Password Change	User Name (Managing Passwords) Device Name Device Serial Number User Name Affected Completion Status (Password Modified)
91	Embedded Fax Job Secure Print Passcode	User Name (Managing Passcodes) Device Name Device Serial Number Completion Status (Passcode Created/Changed)

92	Scan to Mailbox Folder Password	User Name (Managing Passwords) Device Name Device Serial Number Folder Name Completion Status (Password was Changed)
93	Embedded Fax Mailbox Passcode	User Name (Managing Passcodes) Device Name Device Serial Number Completion Status (Passcode Created/Changed)
94	FTP/SFTP Filing Passive Mode	User Name Device Name Device Serial Number Completion Status (Enabled/Disabled)
95	Embedded Fax Forwarding Rule	User Name Device Name Device Serial Number Fax Line 1 or 2 (if applicable) Completion Status (Rule Edit/Rule Enabled/Rule Disabled)
96	Allow Weblet Installation	User Name Device Name Device Serial Number Completion Status (Enable Installation/Block Installation)
97	Weblet Installation	User Name Device Name Device Serial Number Weblet Name Action (Install/Delete) Completion (Success/Fail)
98	Weblet Enablement	User Name Device Name Device Serial Number Weblet Name Completion Status (Enable/Disable)
99	Network Connectivity Configuration	User Name Device Name Device Serial Number Completion Status (Enable Wireless/Disable Wireless/Configure Wireless/Enable Wired/Disable Wired/Configure Wired/Enable WiFi Direct/Disable WiFi Direct/Configure WiFi Direct)
100	Address Book Permissions	User Name Machine Name Machine Serial Number Completion Status (SA Only/Open Access Enabled WebUI/ (SA Only/Open Access Enabled LocalUI)

101	Address Book Export	User Name Machine Name Machine Serial Number
102	SW Upgrade Policy	User Name Device Name Device Serial Number Completion Status (Enable Installation/Disable Installation)
103	Supplies Plan Activation	Device Name Device Serial Number Completion Status Success (if Passcode is okay) Failed (if Passcode is not okay) Locked out (if Max Attempts Exceed 5) Time Remaining Hrs (remaining for next attempt) Min (remaining for next attempt)
104	Plan Conversion	Device Name Device Serial Number
		Completion Status Success (if Passcode is okay) Failed (if Passcode is not okay) Locked out (if Max Attempts Exceed 5) Time Remaining Hrs (remaining for next attempt) Min (remaining for next attempt)
105	IPv4 Configuration	User Name Device Name Device Serial Number Completion Status (Enabled Wireless/Disabled Wireless/Configured Wireless/Enabled Wired/Disabled Wired/Configured Wired)
106	SA PIN Reset	Device Name Device Serial Number Completion Status (Success/Failed)
107	Convenience Authentication Login	User Name Device Name Device Serial Number Completion Status (Success/Failed)
108	Convenience Authentication Configuration	User Name Device Name Device Serial Number Completion Status (Enabled/Disabled/Configured)
109	Embedded Fax Passcode Length	User Name (Managing Passcodes) Device Name Device Serial Number Completion Status (Passcode Length Changed)

110	Custom Authentication Login	User Name Device Name Device Serial Number Completion Status (Success/Failed)
111	Custom Authentication Configuration	User Name Device Name Device Serial Number Completion Status (Enabled/Disabled/Configured)
112	Billing Impression Mode	User Name Device Name Device Serial Number Mode Set to (A4 Mode/A3 Mode) Completion Status (Success/Failed)
114	Clone File Installation Policy	User Name Device Name Device Serial Number Completion Status (Enable for Encrypted Files Only/Disable)
115	Save for Reprint Job	Job Name User Name Source (Print from USB/Print from URL/Print Protocol   Web UI) Completion Status
116	Web User Interface Access Permission	User Name Device Name Device Serial Number Completion Status (Standard Access/Open Access/Restricted)
117	System Log Push to Xerox	Username, if Authenticated Server Destination URL Log Identifier String (Filename) Completion Status (Success/Failed)
120	Mopria Print Enablement	User Name Device Name Device Serial Number Completion Status (Enabled/Disabled)
123	Near Field Communication (NFC) Enablement	User Name Device Name Device Serial Number Completion Status (Enabled/Disabled)
124	Invalid Login Attempt Lockout	Device Name Device Serial Number Interface (WebUI, Local UI   SNMP   Remote   Fax   Secure Fax) Session IP Address (if available)
125	Secure Protocol Log Enablement	User Name Device Name Device Serial Number Completion Status (Enable/Disable)

126	Display Device Information Configuration	User Name Device Name Device Serial Number Completion Status (Configured)
127	Login Attempt After Lockout Expired	Device Name Device Serial Number Interface (WebU/Local UI) Session IP Address (if available) Count of Invalid Attempts: xx attempts, where xx = the number of attempts
128	Erase Customer Data	Device Serial Number Completion Status (Success/Failed)
129	Audit Log SFTP Scheduled Configuration	User Name Device Name Device Serial Number Completion Status (Enable/Disable/Configured)
130	Audit Log SFTP Transfer	User Name Device Name Device Serial Number Destination Server Completion Status (File Transmitted)
131	Remote Software Download Policy	User Name Device Name Device Serial Number
		Completion Status (Enabled/Disabled)
132	AirPrint & Mopria Scanning Configuration	User Name Device Name Device Serial Number Completion Status (Enable/Disable/Configured)
133	AirPrint & Mopria Scan Job Submitted	Job Name (if accepted) User Name (if available) IP Address of Submitting Client Device Name Device Serial Number Completion Status (Accept/Reject Request)
134	AirPrint & Mopria Scan Job Completed	Job Name User Name (if available) Completion Status
136	Remote Services NVM Write	Device Name Device Serial Completion Status (Success/Fail)

137	FIK Install via Remote Services	Device Name Device Serial Completion Status (Success/Fail) User-readable names for the features being installed
138	Remote Services Data Push	Device Name Device Serial Completion Status (Success/Fail)
139	Remote Services Enablement	User Name Device Name Device Serial Status (Enabled/Disabled)
140	Restore Backup Installation Policy	User Name Device Name Device Serial Number Completion Status (Enabled/Disabled)
141	Backup File Downloaded	File Name User Name Interface (WebUI) IP Address of the Destination (if applicable) Completion Status (Success/Failed)
142	Backup File Restored	File Name User Name Device Name Device IP address Interface (WebUI) Completion Status (Success/Failed)
144	User Permission Role Assignment	User Name Device Name Device Serial Number User or Group Name (Assigned) Role Name Action (Added/Removed)
145	User Permission Role Configuration	User Name Device Name Device Serial Number Role Name Completion Status (Created/Deleted/Configured)
146	Admin Password Reset Policy Configuration	User Name Device Name Device Serial Number
147	Local User Account Password Policy	User Name Device Name Device Serial Number

148	Restricted Administrator Login	User Name Device Name Device Serial Number Completion Status (Success/Failed)
149	Restricted Administrator Role Permission	User Name (of user making the change) Device Name Device Serial Number User Name (of target user) Action (Grant/Revoke)
150	Logout	Device Name Device Serial Number Interface (WebUI, LUI, CAC) User Name (who was logged out) Session IP (if available)
151	IPP Configuration	User Name Device Name Device Serial Number Completion Status (Enabled/Disabled/Configured)
152	HTTP Proxy Server Configuration	User Name Device Name Device Serial Number Completion Status (Enabled/Disabled/Configured)
153	Remote Services Software Download	Device Name Device Serial Number Completion Status (Success/Failed) File Name
154	Restricted Admin Permission Role Configuration	User Name Device Name Device Serial Number Restricted Admin Role Name Completion Status (Created/Deleted/Configured)
155	Weblet Installation Security Policy	User Name Device Name Device Serial Number Policy (Allow Installation of Encrypted Weblets/Allow Installation of Both Encrypted and Unencrypted Weblets)
156	Lockdown and Remediate Security Enablement	User Name Device Name Device Serial Number Completion Status (Enabled/Disabled)
157	Lockdown Security Check Complete	User Name Device Name Device Serial Number Completion Status (Success/Failed)

158	Lockdown Remediation Complete	User Name Device Name Device Serial Number Completion Status (Success/Failed)
159	Send Engineering Logs on Data Push	User Name (if available) Device Name Device Serial Number Current Setting (Enabled/Disabled)
160	Print Submission of Clone Files Policy	User Name (if available) Device Name Device Serial Number Completion Status (Enabled/Disabled/Permanently Removed)
161	Network Troubleshooting Data Capture	User Name Device Name Device Serial Number Completion Status (Started/Stopped)
162	Network Troubleshooting Data Download	User Name File Name (of downloaded file) Device Name Device Serial Number Destination (IP Address) Completion Status (Success/Failed)
163	DNS-SD Record Data Download	User Name File Name (of downloaded file) Device Name Device Serial Number Destination (IP address) Completion Status (Success/Failed)
164	One-Touch App Management	User Name Device Name Device Serial Number 1-Touch Application Display Name Action (Install/Un-install) Completion Status (Success/Failed)
165	SMB Browse Enablement	User Name Device Name Device Serial Number Completion Status (Enabled/Disabled/Configured)
166	Standard Job Data Removal Started	Device Name Device Serial Number
167	Standard Job Data Removal Complete	Device Name Device Serial Number Completion Status (Success/Failed)
168	Full Job Data Removal Started	Device Name Device Serial Number

169	Full Job Data Removal Complete	Device Name Device Serial Number Completion Status (Success/Failed)
170	Scheduled Job Data Removal Configuration	User Name Device Name Device Serial Number Completion Status (Enable/Disable/Configured/Schedule Frequency Configured/Schedule Minute Of Day Configured/Schedule Day Of Month Configured/Schedule Day Of Week Configured/Schedule Mode Configured)
171	Cross-Origin Resource Sharing (CORS)	User Name Device Name Device Serial Number Completion Status (Enabled/Disabled)
172	One-Touch App Export	User Name Device Name Device Serial Number Completion Status (Success/Failed)
173	Fleet Orchestrator Trust Operations	User Name Device Name Device Serial Number Member Name Member Serial Number TC Lead Device Name TC Lead Serial Number Trust Operation (Grant/Revoke) Completion Status (Success/Failed)
174	Fleet Orchestrator Configuration	User Name Device Name Device Serial Number Trust Operation (Enable/Disable/Configure) Completion Status (Success/Failed)
175	Fleet Orchestrator - Store File for Distribution	User Name Device Name Device Serial Number File type (SWUP/Clone/Add-On) File Name
176	Configuration Watchdog Enablement	User Name Device Name Device Serial Number Completion Status (Enabled/Disabled)
177	Configuration Watchdog Check Complete	User Name (if available, SYSTEM, if executed as a scheduled event) Device Name Device Serial Number
		Completion Status (Success/Failed)

178	Configuration Watchdog Remediation Complete	User Name (if available, SYSTEM, if executed as a scheduled event) Device Name Device Serial Number Completion Status (Success/Failed)
179	ThinPrint Configuration	User Name Device Name Device Serial Number Completion Status (Enabled/Disabled/Configured)
180	iBeacon Active	User Name Device Name Device Serial Number Completion Status (Enabled/Disabled)
181	Network Troubleshooting Feature	User Name Device Name Device Serial Number Completion Status (Installed/Uninstalled)
182	POP3 Connection Encryption (TLS)	User Name Device Name Device Serial Number Completion Status (Enabled/Disabled/Configured)
183	FTP Browse Configuration	User Name Device Name Device Serial Number Completion Status (Configured/Enabled/Disabled)
184	SFTP Browse Configuration	User Name Device Name Device Serial Number Completion Status (Configured/Enabled/Disabled)
189	Smart Proximity Sensor "Sleep on Departure" Enablement	User Name Device Name Device Serial Number Completion Status (Enabled/Disabled)
190	Cloud Browsing Enablement	User Name Device Name Device Serial Number Feature (Scan to Cloud/Print from Cloud) Interface (WebUI/SNMP) Session IP Address Completion Status (Enabled/Disabled)
192	Scan to Cloud Job	Job Name User Name Cloud Service Completion Status IIO Status Accounting User ID Name Accounting Account ID Name

193	Xerox Workplace Cloud Enablement	User Name Device Name
		Device Serial Number Completion Status (Enabled/Disabled)
194	Scan to Save FTP and SFTP Credentials Policy Configured	User Name Device Name Device Serial Number Completion Status (Never/Always/Prompt)
195	Card Reader	Device Name Device Serial Number Completion Status (Connected/Disconnected)
196	EIP App Management	User Name Device Name Device Serial Number App Name Action (Install/Delete) Completion Status (Success/Failed)
197	EIP App Enablement	User Name Device Name Device Serial Number App Name Completion Status (Enabled/Disabled)
199	Card Reader Upgrade Policy	User Name Device Name Device Serial Number Completion Status (Enabled/Disabled)
200	Card Reader Upgrade Attempted	User Name Device Name Device Serial Number Completion Status (Success/Failed) Card Reader Upgrade File Name Card Reader Serial Number
201	OCSF Responder Incomplete	User Name Device Name Device Serial Number Service or Feature Certificate Serial Number Responder Address Completion Status (No Connection/Unknown/Internal Error)
202	OCSF Responder Returns a 'Revoked' Status	User Name Device Name Device Serial Number Service or Feature Certificate Serial Number Responder Address

203	Log Enhancement	User Name Device Name Device Serial Number Completion Status (Started/Stopped) Interface (WebUI/Remote Services) IPv4 or IPv6 Address (if available)
204	Syslog Server	User Name Device Name Device Serial Number Server Address (if available) Completion Status (Configured/Enabled/Disabled)
205	TLS Configuration	User Name Device Name Device Serial Number Completion Status (Configured)
206	Security Dashboard Configuration	User Name Device Name Device Serial Number Completion Status (Configured)
208	Canceled Job	Job Name User Name IIO Status Accounting User ID Accounting Account ID
209	Embedded Accounts	User Name Device Name Device Serial Number Completion Status (Enabled/Disabled)
210	SNMP v1/v2c	User Name Device Name Device Serial Number Completion Status (Configured/Enabled/Disabled)
211	Xerox Workplace Cloud Management	User Name Device Name Device Serial Number Completion Status (Enabled/Disabled)
216	Infrared Security Configuration	User Name Device Name Device Serial Number Action (Mark Feature Setup/Marking Setup/Mark Detection Setup) Completion Status (Configured/Enabled/Disabled)

217	Infrared Security Mark Detected	User Name Device Name Device Serial Number Job Name Detected Mark Symbol Type Detected Mark Symbol Label Detection App (Copy/Email/ScanTo/Workflow Scanning) Completion Status (Job Inhibited & Email Sent/Job Inhibited Only/Only Email Sent/Audit Log Only)
218	Universal Print Enablement	User Name Device Name Device Serial Number Universal Print Completion Status (Enabled/Disabled) Session IP Address (If Available)
219	Universal Print Registration	User Name Device Name Device Serial Number Universal Print Registration Status (Registered/Unregistered/Certificate expired/Registration claim code expired) Session IP Address (If Available)
220	IdP Authentication Login Attempt	User Name Device Name Device Serial Number Completion Status (Success)
221	IdP Authentication Enablement	User Name Device Name Device Serial Number Completion Status (Enabled/Disabled)
222	Increased Data Analysis	User Name Device Name Device Serial Number Completion Status: (Started   Stopped) Session IP Address (If Available)